



Totally Focused. Totally Independent.

Technical Guide

ECP34/4 A

The world's largest
independent producer of
alternators 1 – 5,000kVA

Standards

Alternators are designed and produced within an ISO 9001 environment. The entire series is manufactured according to, and complies with, the most common specifications such as CEI 2-3, IEC 34-1, EN 60034-1, VDE 0530, BS 4999-5000, NF 51.111, CAN/CSA-C22.2 No14-95-No100-95, NEMA MG 1-2011, ISO 8528-3. Other standards such as UL1446, UL 1004/4 and /B are available on request.

Windings and Performances

All windings are 2/3rds pitch to eliminate triplen harmonics within the voltage waveform and to avoid excessive neutral currents in certain parallel operating conditions. A fully interconnected aluminium or copper damper cage is supplied on the rotor of all models (excluding the ECP3 series).

- ▶ 12 wire reconnectable:
 - 50Hz – 380V to 440V and 220/110V to 240/120V (de-rates may apply at certain voltages)
 - 60Hz – 380V to 480V and 220/110V to 240/120V (de-rates may apply at certain voltages)
- ▶ 6 wire reconnectable:
 - 50Hz – 380V to 440V and 220V to 240V (de-rates may apply at certain voltages)
 - 60Hz – 380V to 480V and 220V to 240V (de-rates may apply at certain voltages)

Winding Configurations	Standard		Special (dedicated)			
	12 wire Reconnectable	6 wire Reconnectable	380V and 600V 60Hz	690V 50/60Hz	220-240V 1ph 50Hz	220-240V 1ph 60Hz
ECP3 to ECO38	Std	Option	Option	Option	Option	Option
ECO40 to ECO46	Std	Option	Option	Option	Option (to ECO40)	Option (to ECO40)
Insulation materials	Class H	Class H	Class H	Class H	Class H	Class H
High efficiency	Std	Std	Std	Std	Std	Std
High motor starting	>300%	>300%	>300%	>300%	>300%	>300%
THD (Total Harmonic Distortion)	Typically <3.5% full load L-L	Typically <3.0% full load L-L	Typically <3.5% full load L-L	Typically <3.5% full load L-L	Typically <4.5% full load L-N	Typically <4.5% full load L-N
Interference suppression	VDE 0875 G/N/K, EN61000-6-3, EN61000-6-2, others available on request					

Winding Protection

There are various degrees of protection for the windings following the standard impregnation process, as can be seen here. The TOTAL or TOTAL+ butadienic black flexible coating is recommended for arduous applications.

Winding Protection:	STANDARD	STANDARD+	GREY	TOTAL (3% de-rate may apply on certain models)	TOTAL+ (3% de-rate may apply on certain models)
ECP3	Std	Option	Option	Option	Option
ECP28, NPE32 and ECP32	-	Std	Option	Option	Option
ECP34 to ECO46	-	-	Std	Option	Option

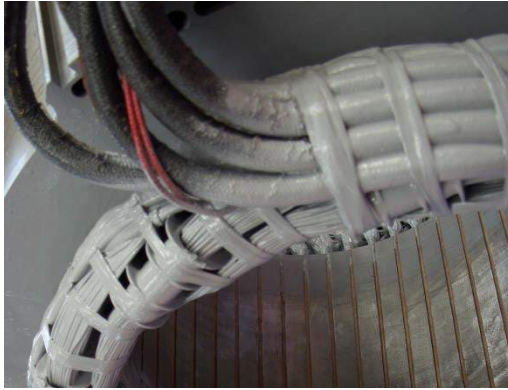

Grey treatment (marinization) on the left, TOTAL treatment shown on the right. The EG43 grey varnish, is an high temperature insulating enamel that forms a tough and flexible film, with excellent moisture and chemical protection. It is water and oil proof, and also protects windings from abrasion. It is applied spraying an over coating layer over the impregnated winding, or dipping the stator in a varnish barrel for superior treatments

The TOTAL is a protection system that makes Mecc Alte special. It is the ultimate winding treatment that offers truly superior performances when the environment is really harsh, or the application very demanding. It is a rubbery protection treatment, used to replace epoxies and silicones winding encapsulation. The TOTAL flexible black compound cures to a tough, resilient, glossy black thick coating that seals the copper against moisture and chemical attacks. Due to its encapsulation capability and flexibility, is also extremely resistant to the particle abrasion as it adsorbs the impacts. Moreover, the high flexibility leads to a long-trouble less life protection, as the compound follows elastically the thermal expansion cycles of the windings from the cold to the hot condition and vice versa without forming any cracks.

Protection for Environment

In addition to protection on the windings themselves, the alternators can have increased ingress protection. Standard levels are IP23 with further upgrades available to include inlet filters, IP43 and IP45: 7% de-rates apply on inlet filters and IP43 protection. 20-30% de-rates apply for IP45 depending on alternator model.

Additional air exit louvres (called IP23+) are optionably retrofittable in the overall ECP32 to ECO 46 range, in order to comply to the most strict marine regulations.



Construction

The robust mechanical structure withstands up to 5G in any direction and 9G vertically and its design permits easy access to the connections and components during routine maintenance check-ups. The mechanical design has used the most advanced FEM techniques. The materials used are: FEPI2 steel for the frame, C45 steel for the shaft and cast iron or aluminum pressure die cast for the end-brackets: fans are aluminum die casted either nylon fiber glass loaded, UL compliant materials. Rotors are dynamically balanced according grade 2.5 of ISO 1940-1.

Terminals and Terminal Box

Easy access to regulators is assured through a pull out drawer or a drop down panel to allow safer adjustment. Large terminal boxes allow easy access of power cables, in the ECO43 and ECO46 higher power ranges the terminal allow the convenient choice of power cable or busbar connection with versatility of entry and connection. Current transformers are available as an option on series ECO 40, 43 and 46 with single or dual output.

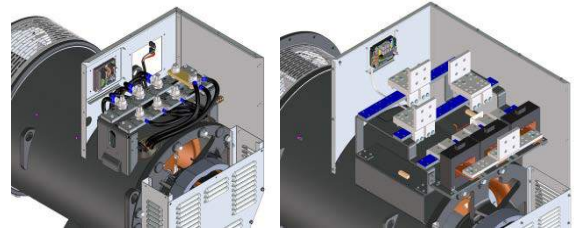

Excitation and Regulation Systems

All ECP/ECO series have MAUX auxiliary winding to power the digital regulator. Both DSR and the DER1 are available to connect to PC through the DxR2 USB interface and DxR TERMINAL software to interrogate/download alarms & settings for analysis or for cloning other regulators. DER2 has got an integrated USB connection and can be connected to the PC without any optional connection boards. More settings such as LAMS, digital RAM based synchronous external control and soft start are obtainable through the DxR connection. Simple analogue potentiometers are available for the more usual adjustments.

Excitation Systems	DSR	DER1	DER2
ECP3 to ECO38	Std	Option	Option
ECO40 to ECO46	-	Std	Option
Parallel Operation	√	√	√
Mains Parallel	√	√	√
3 Phase Sensing (rms)	-	√	√
Accuracy	+/-1%	+/-0.5%	+/-0.5%
Remote Voltage Control	√	√	√
Alarm Log	√	√	√
Analogue and Digital Configurable	√	√	√
LAMS (Load Acceptance V/f)	√	√	√
APO (Active Protection Output)	√	√	√
Soft Start	√	√	√
High dynamic response	-	-	√
USB connection without external boards	-	-	√

For a given motor start duty a smaller machine may be selected – also enhanced by low sub-transient reactance values for non-linear loads. The whole range from 6.5 to 3400kVA is capable of >300% sustained short circuit current for up to 20 seconds.

Optional PMG3

PMG3 can be retro fit or factory fit on ECO 40, 43 and 46 series. This smart MeccAlte design allows an easy fix kit, through a tapered cone coupling and a simple replacement of the rear air louvre. PMG3 is also available on ECO 38, when ordered from the factory.

The complete AVR range is fully compatible with both MAUX and PMG3 systems, this minimises spare part management and flexibility of stock as one AVR suits all applications. The PMG3 is delivering the same amount of kVA available with the MAUX.

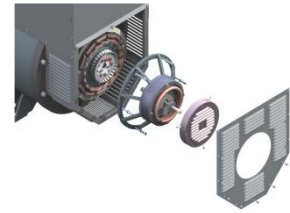

Accessories

Additional optionals can be fit on our alternator series, such as PTC thermistors or PT100 both on windings and bearings, space heaters, high and low profile of terminal boxes (on most series), air filter clogging sensors, rotating diode bridge failure sensor (RBD), power factor controller for parallel operation (PFR/2), parallel devices (standard from ECO 40), air filters, IP43 and IP45 protections, marine IP23 + protection for SOLAS requirements and many others.

Deration coefficients

Altitude (meters)	Ambient temperature (Celsius)					
	25	40	45	50	55	60
≤ 1000	1.07	1	0.96	0.93	0.91	0.89
$> 1000 \leq 1500$	1.01	0.96	0.92	0.89	0.87	0.84
$> 1500 \leq 2000$	0.96	0.91	0.87	0.84	0.83	0.79
$> 2000 \leq 3000$	0.9	0.85	0.81	0.78	0.76	0.73

Notes on short circuit curves

The indicated coefficients have to be used to correct the three phase short circuit curves values as a function of the rated voltage.

The indicated coefficient have to be used to correct the three phase short circuit curves values as a function of the type of short circuit voltage.

50 Hz		60 Hz	
Voltage	Factor	Voltage	Factor
380	0.93X	415	0.85X
400	1X	440	0.90X
415	1.04X	460	0.95X
440	1.10X	480	1X

	3 phase	2 phase L-L	1 phase L-N
<i>Istantaneous</i>	1X	0.87X	1.30X
<i>Minimum</i>	1X	1.80X	3.20X
<i>Sustained</i>	1X	1.50X	2.50X
<i>Max Duration</i>	20 sec.	10 sec.	4 sec.

All the curves are shown for series or parallel star connection at 400V 50 Hz or 480V 60 Hz. If the unit is reconnected from series to parallel star, the additional coefficient is 2X. From series star to series delta, it is 1.72X. From series star to parallel delta, it is 3.44X.

General Characteristics

Pole number	4	Insulation class	H
Phase Number	3	Protection class	IP23
Number of wires	12	NDE bearing	6311.2RS
Execution	Brushless	DE bearing	6314.2Z
Regulator type	DSR	Maximum overspeed	2250
Winding pitch	2/3	Altitude	0-1000
Winding code	T04055	Balancing	ISO1940-1

Ratings 50Hz

kVA / kW @ Temp. Rise / Ambient °C - 0.8 PF

	STANDBY-163/27				STANDBY-150/40				H-125/40				F-105/40				B-80/40				
Series	380V	400V	415V	440V	380V	400V	415V	440V	380V	400V	415V	440V	380V	400V	415V	440V	380V	400V	415V	440V	
Parallel Star YY	190V	200V	208V	220V	190V	200V	208V	220V	190V	200V	208V	220V	190V	200V	208V	220V	190V	200V	208V	220V	
Series Delta Δ	220V	230V	240V	245V	220V	230V	240V	245V	220V	230V	240V	245V	220V	230V	240V	245V	220V	230V	240V	245V	
Parallel Delta ΔΔ	110V	115V	120V	127V	110V	115V	120V	127V	110V	115V	120V	127V	110V	115V	120V	127V	110V	115V	120V	127V	
ECP34-1S/4 A	kVA	95	95	95	78	90	90	90	75	85	85	85	70	77	77	77	63	68	68	68	56
	kW	76	76	76	62	72	72	72	60	68	68	68	56	61,6	61,6	61,6	50,4	54,4	54,4	54,4	44,8
ECP34-2S/4 A	kVA	116	116	116	94	110	110	110	90	105	105	105	85	95	95	95	77	84	84	84	68
	kW	93	93	93	75	88	88	88	72	84	84	84	68	76	76	76	61,6	67	67	67	54
ECP34-1L/4 A	kVA	148	148	148	124	143	143	143	120	135	135	135	114	121	121	121	103	108	108	108	91
	kW	118	118	118	99	114	114	114	96	108	108	108	91	97	97	97	82	86	86	86	73
ECP34-2L/4 A	kVA	164	164	164	136	158	158	158	131	150	150	150	125	136	136	136	113	120	120	120	100
	kW	131	131	131	109	126	126	126	105	120	120	120	100	109	109	109	90,4	96	96	96	80
ECP34-3L/4 A	kVA	170	175	175	164	164	169	169	158	155	160	160	150	140	145	145	135	124	128	128	120
	kW	136	140	140	131	131	135	135	126	124	128	128	120	112	116	116	108	99	102	102	96

Ratings 60Hz

kVA / kW @ Temp. Rise / Ambient °C - 0.8 PF

	STANDBY-163/27				STANDBY-150/40				H-125/40				F-105/40				B-80/40				
Series	415V	440V	460V	480V	415V	440V	460V	480V	415V	440V	460V	480V	415V	440V	460V	480V	415V	440V	460V	480V	
Parallel Star YY	208V	220V	230V	240V	208V	220V	230V	240V	208V	220V	230V	240V	208V	220V	230V	240V	208V	220V	230V	240V	
Series Delta Δ	240V	254V	265V	277V	240V	254V	265V	277V	240V	254V	265V	277V	240V	254V	265V	277V	240V	254V	265V	277V	
Parallel Delta ΔΔ	120V	127V	133V	138V	120V	127V	133V	138V	120V	127V	133V	138V	120V	127V	133V	138V	120V	127V	133V	138V	
ECP34-1S/4 A	kVA	106	114	114	114	101	108	108	108	95	102	102	102	85,5	92	92	92	76	81	81	81
	kW	85	91	91	91	81	86	86	86	76	82	82	81,6	68,4	73,6	73,6	73,6	60,8	64,8	64,8	64,8
ECP34-2S/4 A	kVA	127	139	139	139	120	132	132	132	115	126	126	126	104	114	114	114	92	101	101	101
	kW	102	111	111	111	96	106	106	106	92	101	101	101	83,2	91,2	91,2	91,2	74	81	81	81
ECP34-1L/4 A	kVA	153	165	178	178	148	159	172	172	140	150	162	162	125	135	146	146	112	120	130	130
	kW	122	132	142	142	118	127	138	138	112	120	130	130	100	108	117	117	90	96	104	104
ECP34-2L/4 A	kVA	163	185	196	196	158	178	189	189	150	170	180	180	132	150	163	163	120	136	144	144
	kW	130	148	157	157	126	142	151	151	120	136	144	144	106	120	130	130	96	109	115	115
ECP34-3L/4 A	kVA	180	202	210	210	174	195	202	202	165	185	192	192	150	160	173	173	132	148	154	154
	kW	144	162	168	168	139	156	162	162	132	148	154	154	120	128	138	138	106	118	123	123

Reactance & Time constants - Class H / 400V

Unsaturated (ref. ENG000034-4)			ECP34-1S/4 A	ECP34-2S/4 A	ECP34-1L/4 A	ECP34-2L/4 A	ECP34-3L/4 A
X_d	Direct-axis synchronous reactance	%	334,7	236,9	228,7	247,2	216,3
X_d'	Direct-axis transient reactance	%	23	18,1	15,9	15,2	17,9
X_d''	Direct-axis subtransient reactance	%	7,62	5,87	7,83	6,39	7,52
X_q	Quadrature-axis synchronous reactance	%	175,6	154,1	140,1	125,8	147,3
X_q'	Quadrature-axis transient reactance	%	175,6	154,1	140,1	125,8	147,3
X_q''	Quadrature-axis subtransient reactance	%	30,4	32,1	29,2	27,3	32
X₂	Negative-sequence reactance	%	19,8	19,1	17,7	17	19,9
X₀	Zero sequence reactance	%	3,71	3,61	2,78	2,58	3,06
Saturated							
X_d	Direct-axis synchronous reactance	%	284,5	201,4	194,4	210,1	183,9
X_d'	Direct-axis transient reactance	%	19,5	15,4	13,5	13	15,2
X_d''	Direct-axis subtransient reactance	%	6,48	4,99	6,65	5,43	6,39
X_q	Quadrature-axis synchronous reactance	%	149,3	131	119,1	106,9	125,2
X_q'	Quadrature-axis transient reactance	%	149,3	131	119,1	106,9	125,2
X_q''	Quadrature-axis subtransient reactance	%	25,8	27,3	24,9	23,2	27,2
X₂	Negative-sequence reactance	%	14,8	16,2	15,1	14,4	16,9
X₀	Zero sequence reactance	%	3,71	3,61	2,78	2,58	3,06
K_{cc}	Short circuit ratio		0,5	0,47	0,45	0,48	0,48
T_d'	Transient time constant	sec	0,042	0,039	0,039	0,04	0,04
T_d''	Subtransient time constant	sec	0,006	0,006	0,008	0,01	0,01
T_{do}	Open circuit time constant	sec	1,5	1,7	1,85	1,9	1,91
T_a	Armature time constant	sec	0,015	0,015	0,017	0,017	0,017

Additional information - Class H / 400V

I_o	Excitation current at no load	A	0,5	0,6	0,6	0,4	0,45
I_c	Excitation current at full load	A	2,3	2,2	2,1	2,4	2,5
Overload long-term			1 hour in a 6 hours period 110% rated load				
Overload per 20 sec.		%	300,0				
Heat dissipation		W	6317	7106	8254	8755	8898
Telephone Interference (THF)			<2	<2	<2	<2	<2
Waveform Distors.(THD) at full load (LL/LN)		%	2,9 / 3	2,8 / 2,9	2,3 / 2,5	2,3 / 2,4	2,4 / 2,5
Waveform Distors.(THD) at no load (LL/LN)		%	1,6 / 1,8	1,8 / 1,9	1,7 / 1,9	1,7 / 1,8	1,7 / 1,8

Reactance & Time constants - Class H / 480V

Unsaturated (ref. ENG000034-4)			ECP34-1S/4 A	ECP34-2S/4 A	ECP34-1L/4 A	ECP34-2L/4 A	ECP34-3L/4 A
X_d	Direct-axis synchronous reactance	%	334,7	236,9	228,7	247,2	223,3
X_d'	Direct-axis transient reactance	%	23	18,1	15,9	15,2	18,5
X_d''	Direct-axis subtransient reactance	%	7,62	5,87	7,83	6,39	7,76
X_q	Quadrature-axis synchronous reactance	%	175,6	154,1	140,1	125,8	152
X_q'	Quadrature-axis transient reactance	%	175,6	154,1	140,1	125,8	152
X_q''	Quadrature-axis subtransient reactance	%	30,4	32,1	29,2	27,3	33,1
X₂	Negative-sequence reactance	%	19,8	19,1	17,7	17	20,5
X₀	Zero sequence reactance	%	3,71	3,61	2,78	2,58	3,16
Saturated							
X_d	Direct-axis synchronous reactance	%	284,5	201,4	194,4	210,1	189,8
X_d'	Direct-axis transient reactance	%	19,5	15,4	13,5	13	15,7
X_d''	Direct-axis subtransient reactance	%	6,48	4,99	6,65	5,43	6,6
X_q	Quadrature-axis synchronous reactance	%	149,3	131	119,1	106,9	129,2
X_q'	Quadrature-axis transient reactance	%	149,3	131	119,1	106,9	129,2
X_q''	Quadrature-axis subtransient reactance	%	25,8	27,3	24,9	23,2	28,1
X₂	Negative-sequence reactance	%	16,8	16,2	15,1	14,4	17,4
X₀	Zero sequence reactance	%	3,71	3,61	2,78	2,58	3,16
K_{cc}	Short circuit ratio		0,5	0,47	0,45	0,48	0,48
T_d'	Transient time constant	sec	0,042	0,039	0,039	0,04	0,04
T_d''	Subtransient time constant	sec	0,006	0,006	0,008	0,01	0,01
T_{do}	Open circuit time constant	sec	1,5	1,7	1,85	1,9	1,91
T_a	Armature time constant	sec	0,015	0,015	0,017	0,017	0,017

Additional information - Class H / 480V

I_o	Excitation current at no load	A	0,7	0,5	0,5	0,5	0,4
I_c	Excitation current at full load	A	2,2	2,2	2,0	2,6	2,5
Overload long-term			1 hour in a 6 hours period 110% rated load				
Overload per 20 sec.		%	300,0				
Heat dissipation		W	5766	6663	7109	7579	7575
Telephone Interference (TIF)			<40	<40	<40	<40	<40
Waveform Distors.(THD) at full load (LL/LN)		%	2,9 / 3	2,8 / 2,9	2,3 / 2,5	2,3 / 2,4	2,4 / 2,5
Waveform Distors.(THD) at no load (LL/LN)		%	1,6 / 1,8	1,8 / 1,9	1,7 / 1,9	1,7 / 1,8	1,7 / 1,8

Efficiencies @ 50Hz

Models		380V 50Hz					400V 50Hz					415V 50Hz					440V 50Hz				
		0.25	0.5	0.75	1	1.1	0.25	0.5	0.75	1	1.1	0.25	0.5	0.75	1	1.1	0.25	0.5	0.75	1	1.1
ECP34-1S/4 A	%	86,2	89,9	91,6	91,4	91,1	86,0	90,0	91,9	91,5	91,1	85,8	90,0	91,8	91,2	90,8	85,8	89,8	91,5	91,0	90,6
ECP34-2S/4 A	%	87,2	90,6	92,2	92,1	92,0	87,0	90,7	92,5	92,2	92,0	86,8	90,7	92,4	91,9	91,6	86,8	90,5	92,1	91,7	91,5
ECP34-1L/4 A	%	88,2	91,6	93,1	92,8	92,5	88,2	91,7	93,4	92,9	92,5	88,1	91,7	93,2	92,6	92,2	88,0	91,6	93,0	92,4	92,0
ECP34-2L/4 A	%	89,2	91,9	93,2	93,1	92,9	89,0	92,0	93,5	93,2	93,0	88,8	92,0	93,4	92,9	92,7	88,8	91,8	93,1	92,7	92,5
ECP34-3L/4 A	%	89,8	92,2	93,4	93,4	93,2	89,6	92,3	93,7	93,5	93,3	89,4	92,3	93,6	93,2	93,0	89,4	92,1	93,3	93,0	92,8

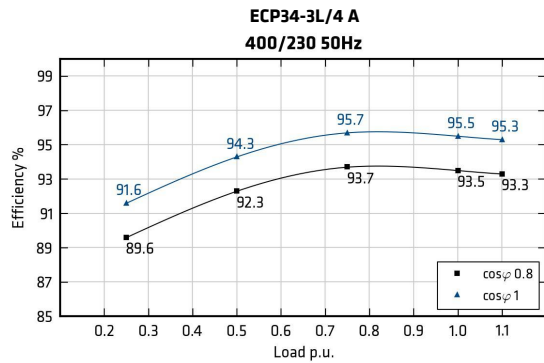
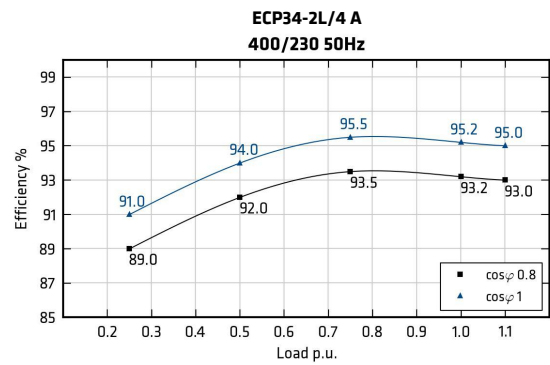
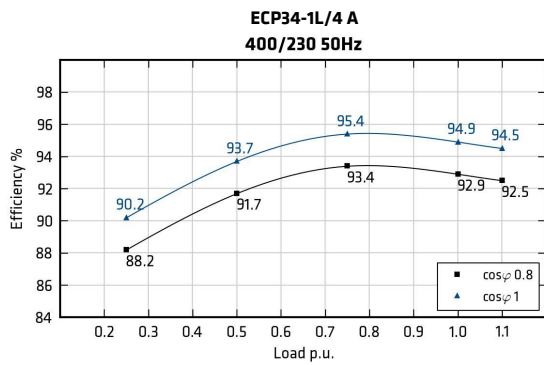
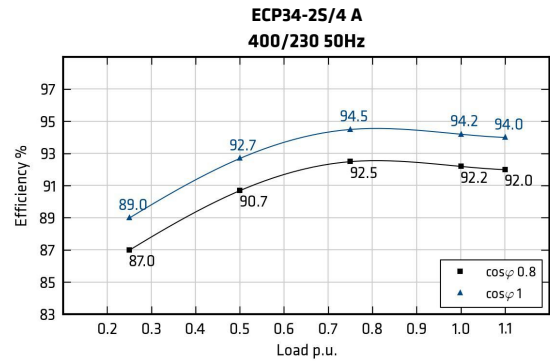
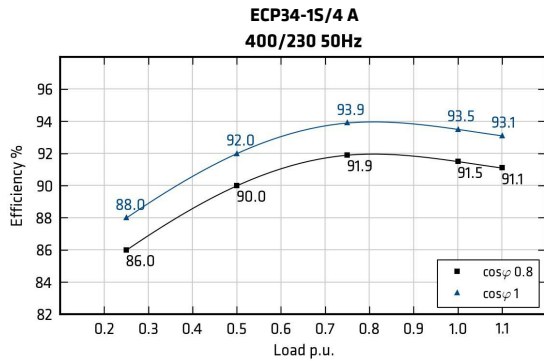

Efficiencies @ 60Hz

Models		415V 60Hz					440V 60Hz					460V 60Hz					480V 60Hz				
		0.25	0.5	0.75	1	1.1	0.25	0.5	0.75	1	1.1	0.25	0.5	0.75	1	1.1	0.25	0.5	0.75	1	1.1
ECP34-1S/4 A	%	87,7	91,5	93,3	92,7	92,2	87,7	91,6	93,5	93,2	93,0	87,7	91,7	93,6	93,3	93,1	87,5	91,8	93,8	93,4	93,1
ECP34-2S/4 A	%	88,2	92,0	93,6	93,1	92,7	88,2	92,1	93,8	93,6	93,4	88,2	92,2	93,9	93,7	93,5	88,0	92,3	94,1	93,8	93,5
ECP34-1L/4 A	%	89,3	93,1	94,5	94,0	93,6	89,4	93,3	95,0	94,5	94,1	89,5	93,5	95,2	94,7	94,3	89,3	93,6	95,3	94,8	94,4
ECP34-2L/4 A	%	90,2	93,5	94,7	94,3	94,1	90,2	93,6	94,9	94,8	94,6	90,2	93,7	95,0	94,9	94,7	90,0	93,8	95,2	95,0	94,8
ECP34-3L/4 A	%	91,2	93,8	95,0	94,6	94,4	91,2	93,9	95,2	95,1	94,9	91,2	94,0	95,3	95,2	95,0	91,0	94,1	95,5	95,3	95,1

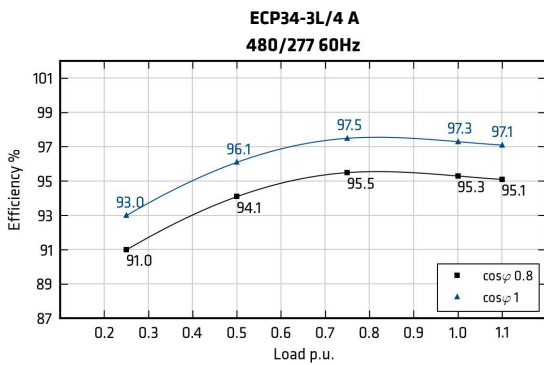
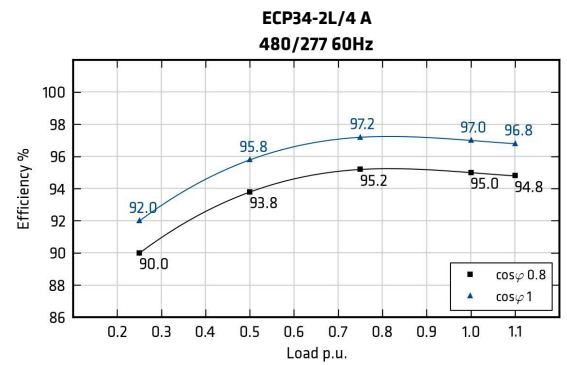
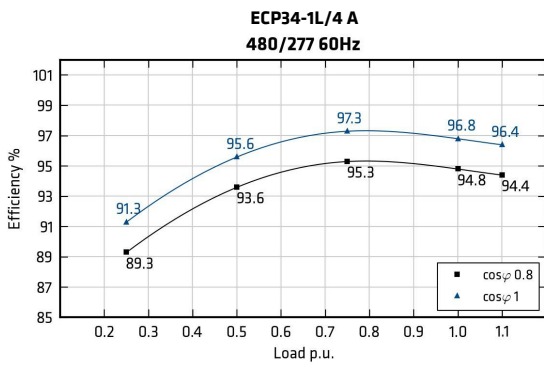
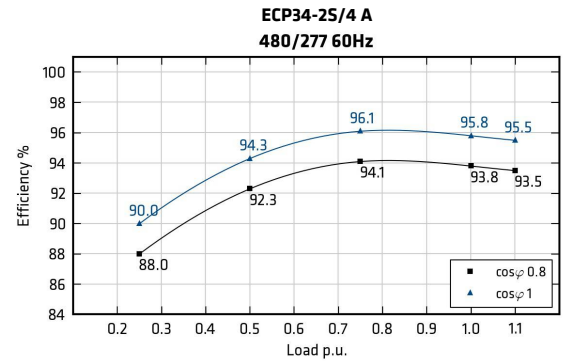
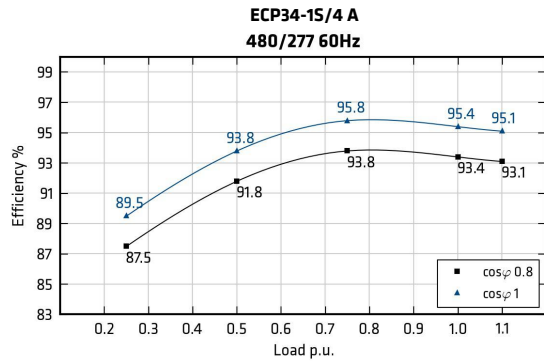

Transients voltage

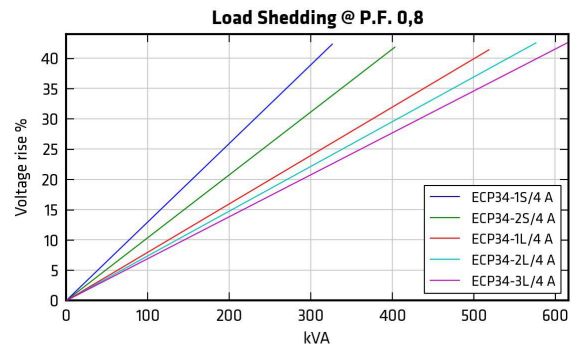
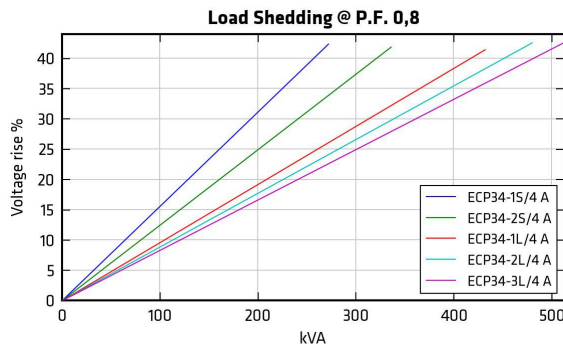
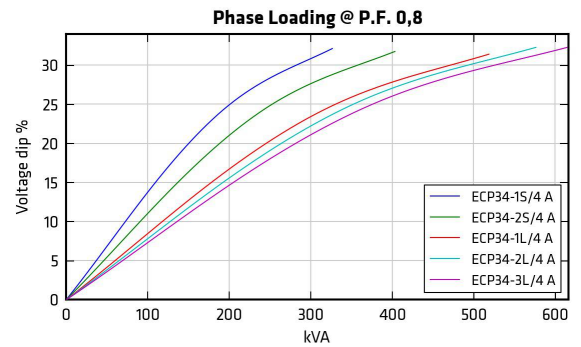
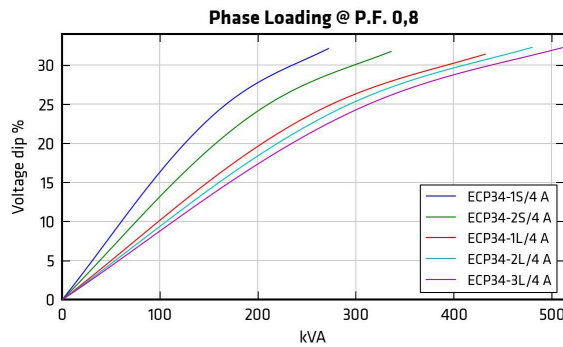
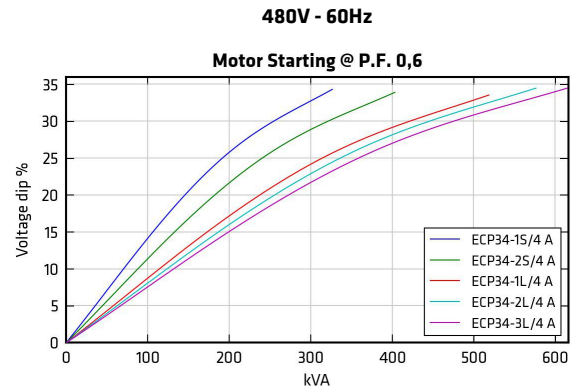

In order to scale transient curves as a function of a power factor or voltage if not indicated, please proceed as follows:

Power Factor coefficient corrector (PFCC), to be used on power factor 0.6 curves:

$$PFCC = \sin(\text{ARCCos}(PF_{\text{new}})) / 0.8$$

Example. The PFCC at power factor 0.3 is 1.192 [$PFCC = \sin(\text{ARCCos}(0.3)) / 0.8$]. This means that the voltage fall at a given power at pf 0.3 is equivalent to the one that can be read on the pf 0.6 curve if the load is considered 1.192 times bigger (19% higher value.).

In this example, a 100 kVA load insertion at pf 0.3 is equivalent in voltage fall to a 119kVA load insertion at pf 0.6.

Voltage coefficient corrector (VCC):

$$VCC = (400/V_{\text{new}})^2 \text{ if } 50 \text{ Hz}; VCC = (480/V_{\text{new}})^2 \text{ if } 60 \text{ Hz}$$

Example. VCC at 415V 60 Hz is 1.338 [$VCC = (480/415)^2$]. This means that the voltage fall at a given power at 415V is equivalent to the one that can be read on the power factor 0.6 curve if the load is considered 1.338 times bigger (33% higher value.).

In this example, a 100 kVA load insertion at 415V is equivalent in voltage fall to a 133kVA load insertion at 480V.

50Hz Short circuit decrement curves - No load excitation at rated speed

ECP34-1S/4 A

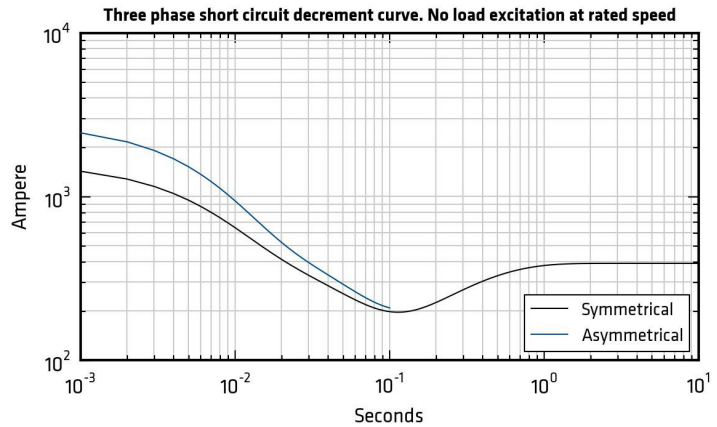

ECP34-2S/4 A

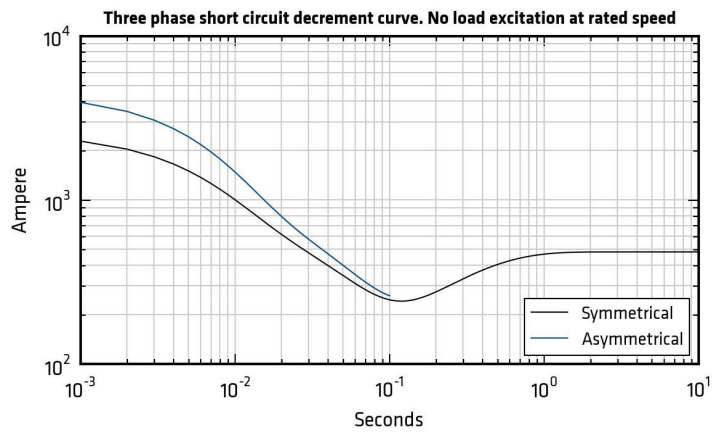

ECP34-1L/4 A

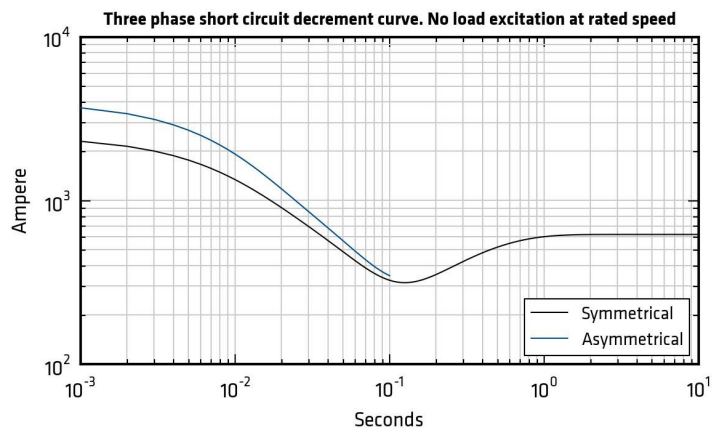

ECP34-2L/4 A

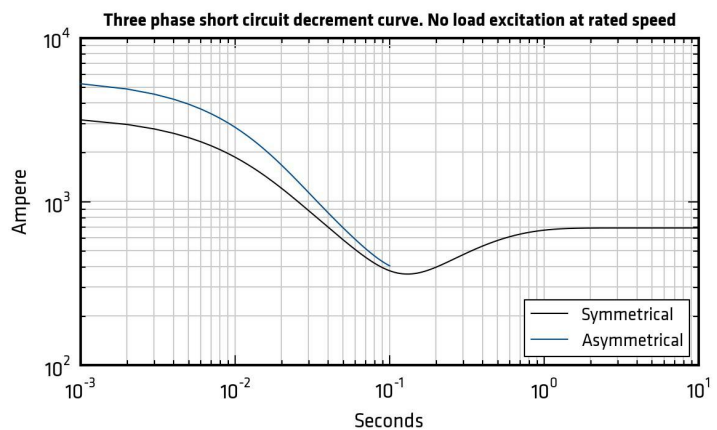

*Please refer to tables at page 6

50Hz Short circuit decrement curves - No load excitation at rated speed

ECP34-3L/4 A

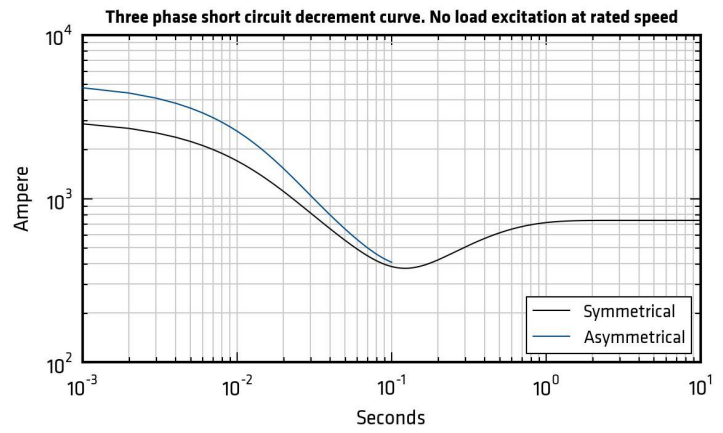

*Please refer to tables at page 6

60Hz Short circuit decrement curves - No load excitation at rated speed

ECP34-1S/4 A

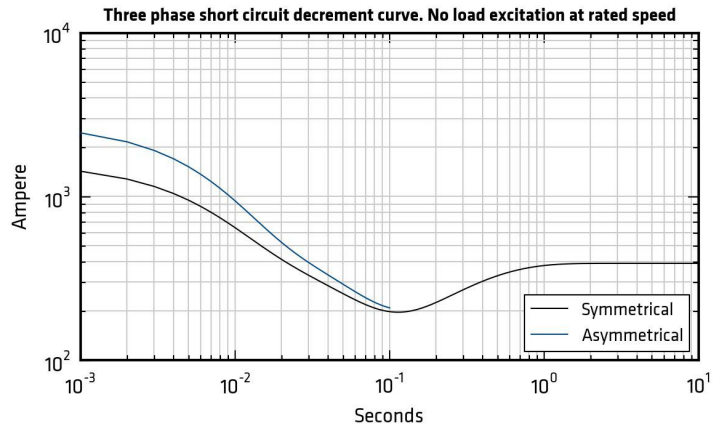

ECP34-2S/4 A

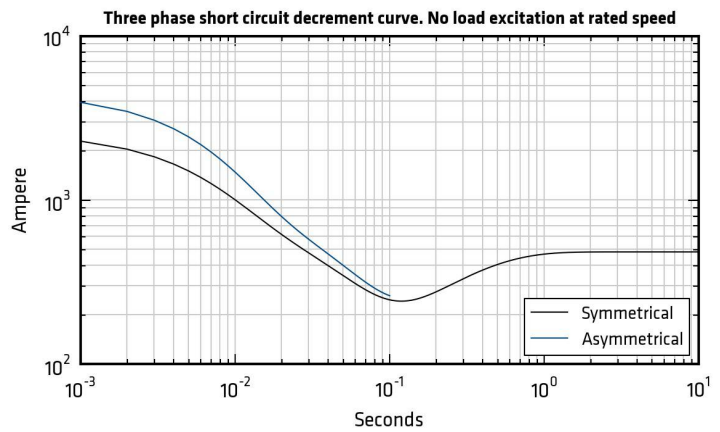

ECP34-1L/4 A

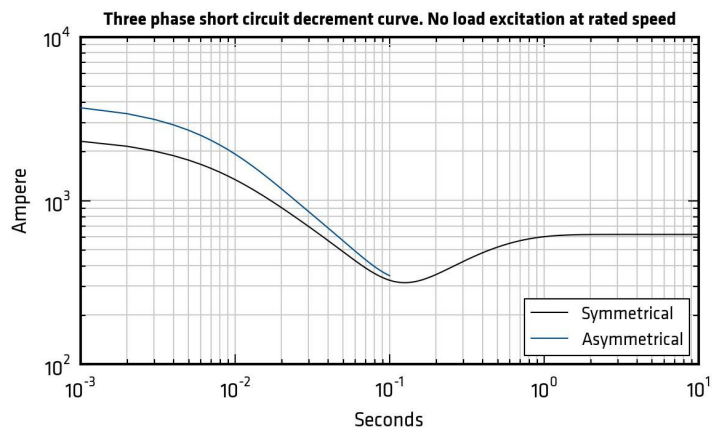

ECP34-2L/4 A

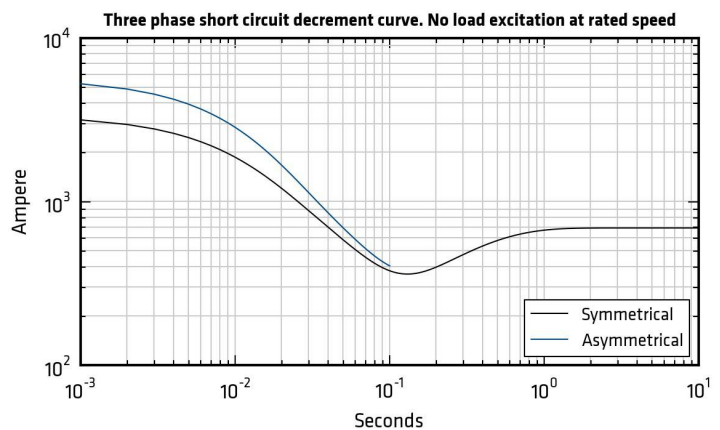

*Please refer to tables at page 6

60Hz Short circuit decrement curves - No load excitation at rated speed

ECP34-3L/4 A

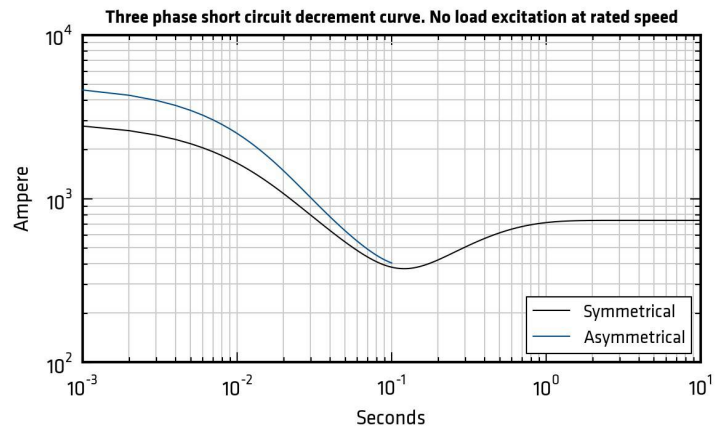

*Please refer to tables at page 6

Additional Characteristics

Data	ECP34-1S/4 A		ECP34-2S/4 A		ECP34-1L/4 A		ECP34-2L/4 A		ECP34-3L/4 A		
	50Hz	60Hz	50Hz	60Hz	50Hz	60Hz	50Hz	60Hz	50Hz	60Hz	
Damper cage	Alluminum										
Stator Winding Resistance (20°C)	Ω	0,03		0,02		0,016		0,015		0,015	
Rotor Winding Resistance (20°C)	Ω	2,477		2,951		4,142		3,577		4,35	
Stator Exciter Resistance (20°C)	Ω	15,28		15,28		15,28		15,28		15,28	
Rotor Exciter Resistance (20°C)	Ω	0,41		0,41		0,41		0,41		0,41	
Weight	Kg	331,0		409,0		467,0		481,0		485,0	
Unbalanced Magnetic pull	kN/mm	4,9		5,1		5,7		5,6		5,4	
Cooling air requirement	m3/min	19,3	23,0	19,3	23,0	19,3	23,0	19,3	23,0	19,3	23,0
Noise Level at 1m/7m	dB(A)	79/65	83/69	79/65	83/69	79/65	83/69	79/65	83/69	79/65	83/69

PQ Diagram

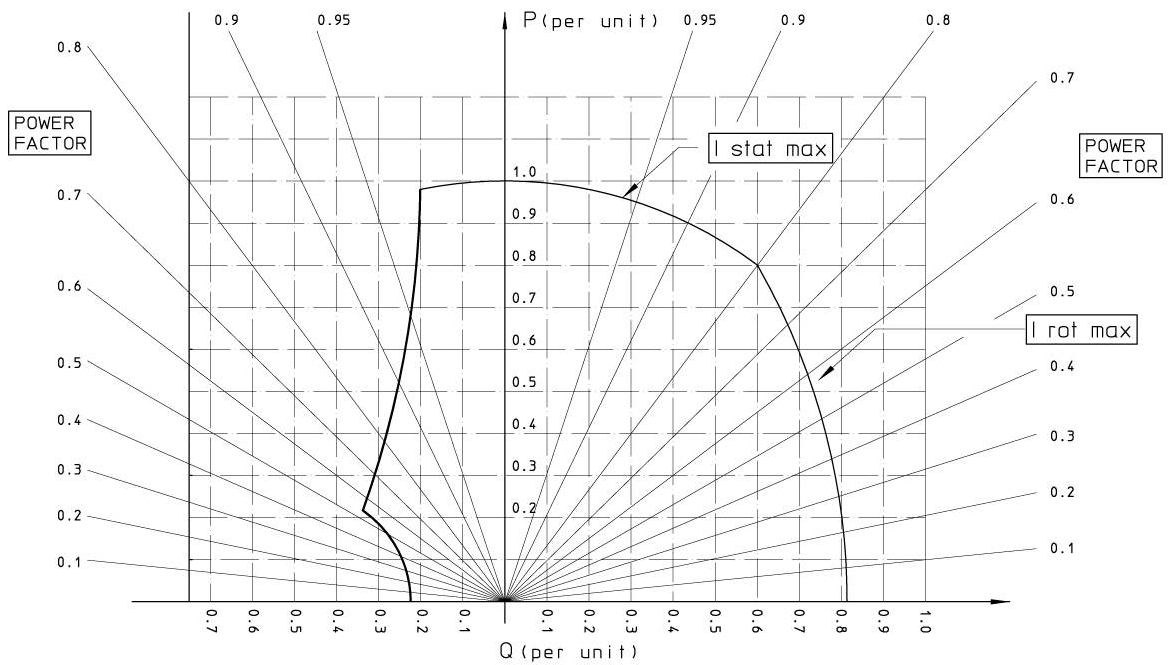

ECP34-1S/4 A

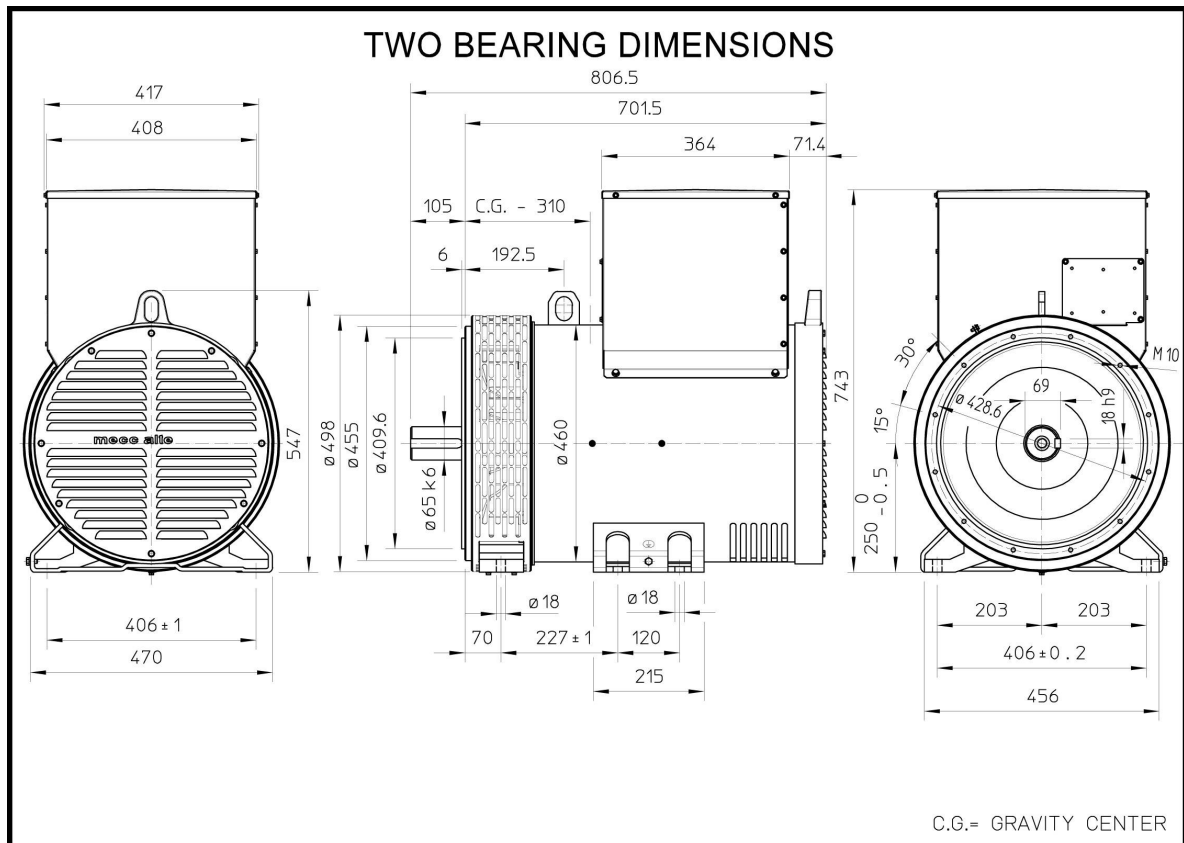
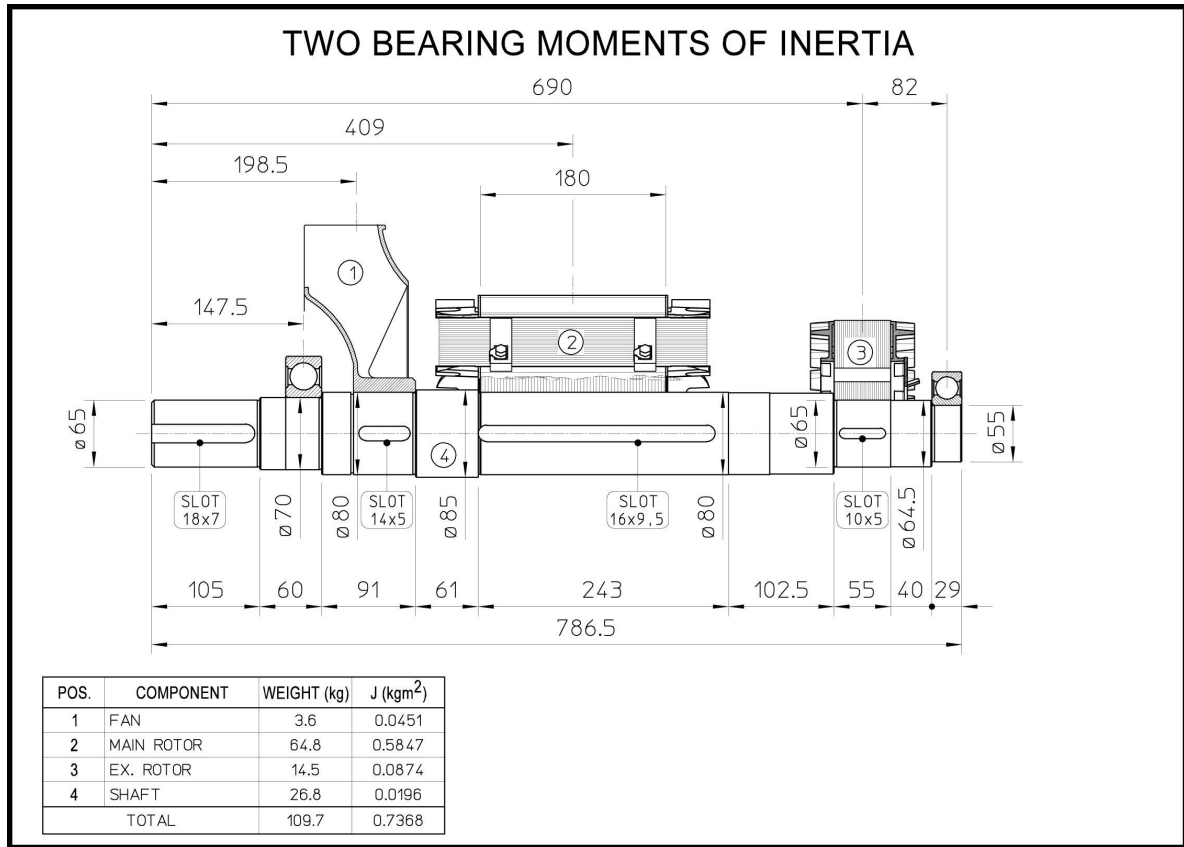

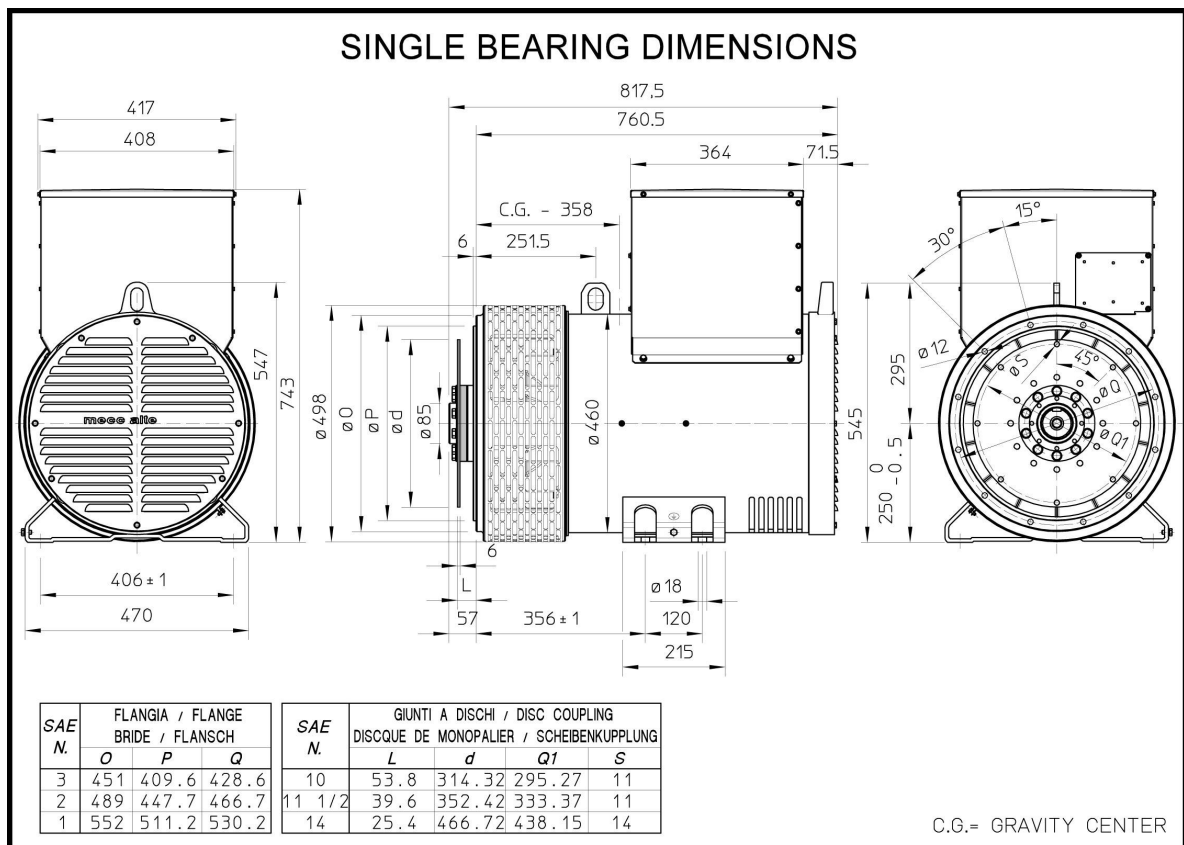
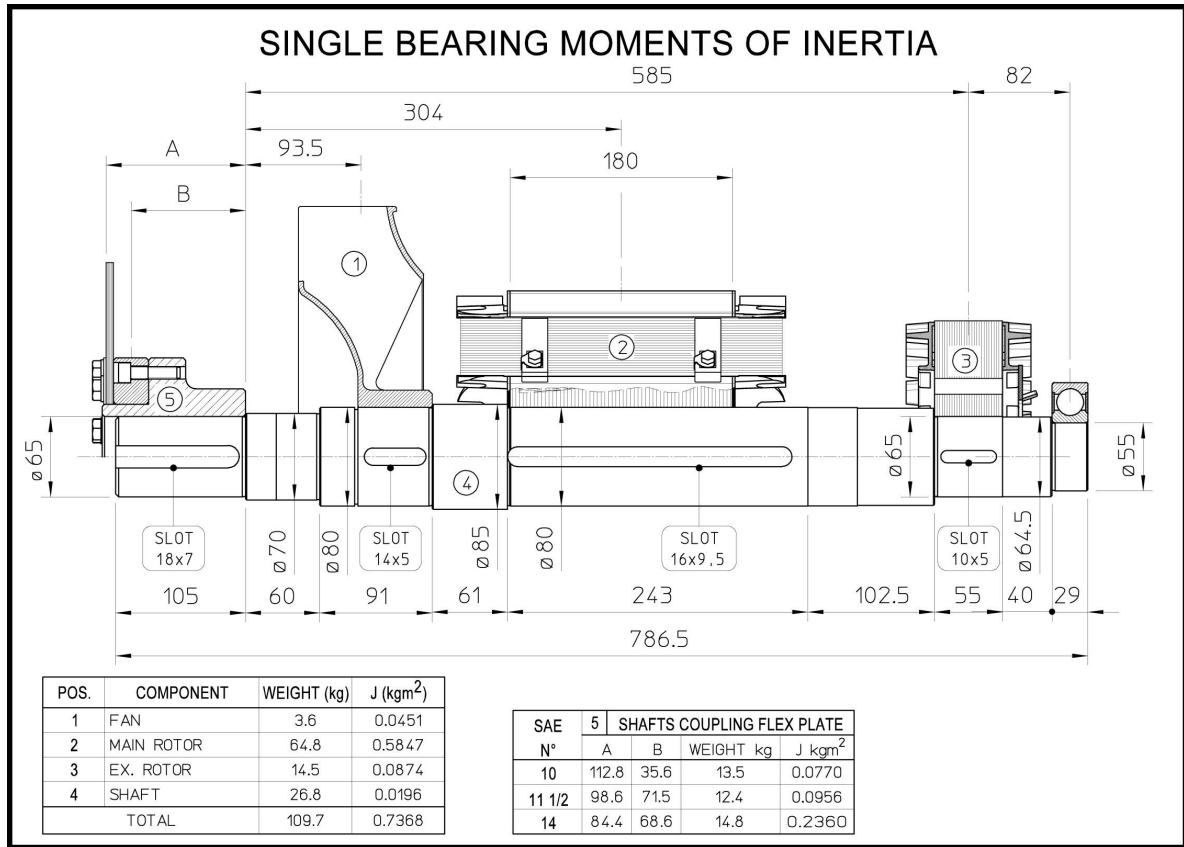

ECP34-2S/4 A

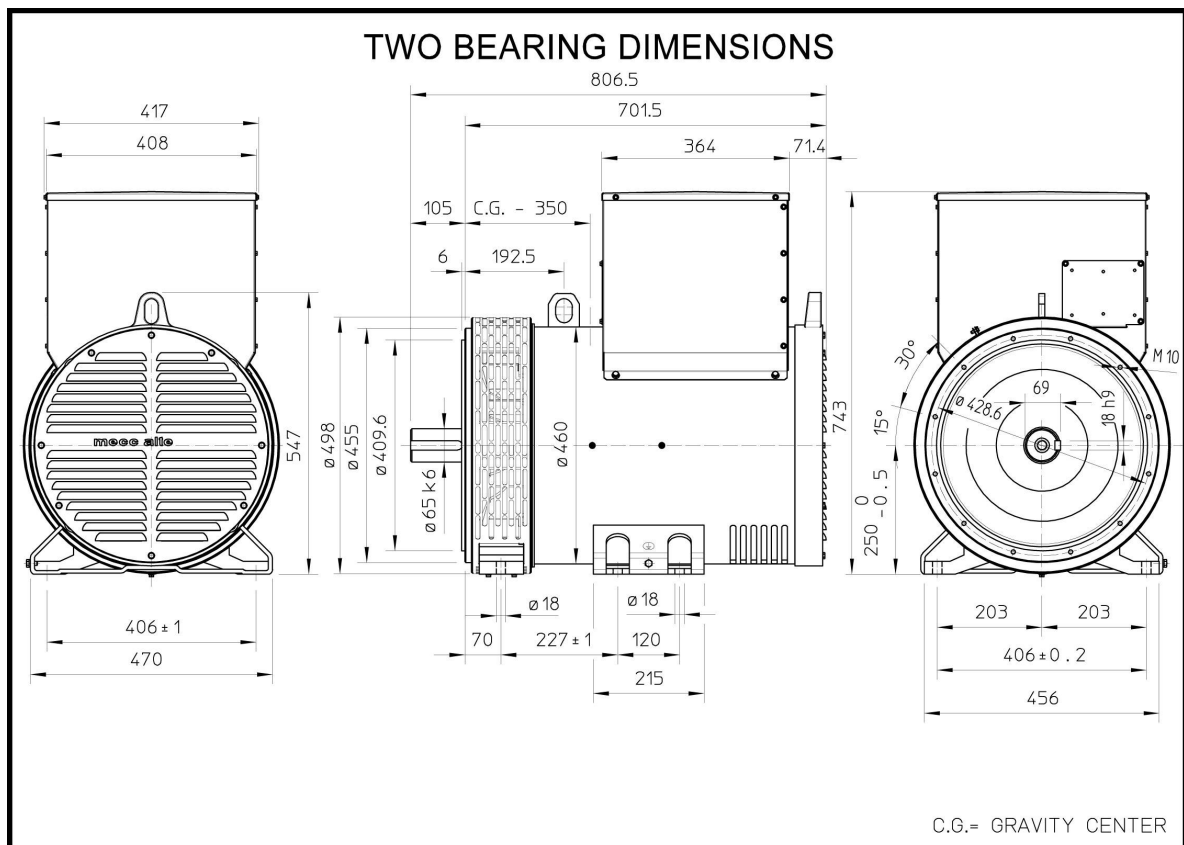
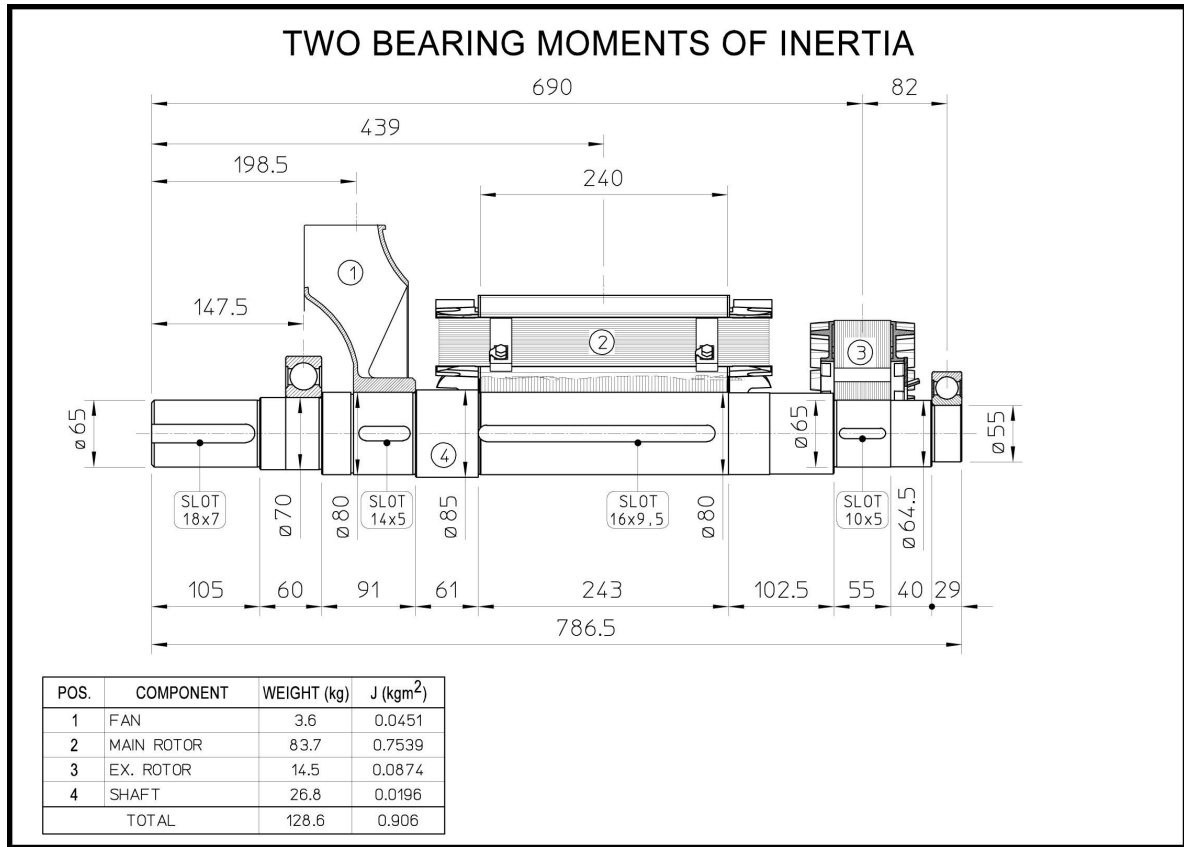

ECP34-2S/4 A

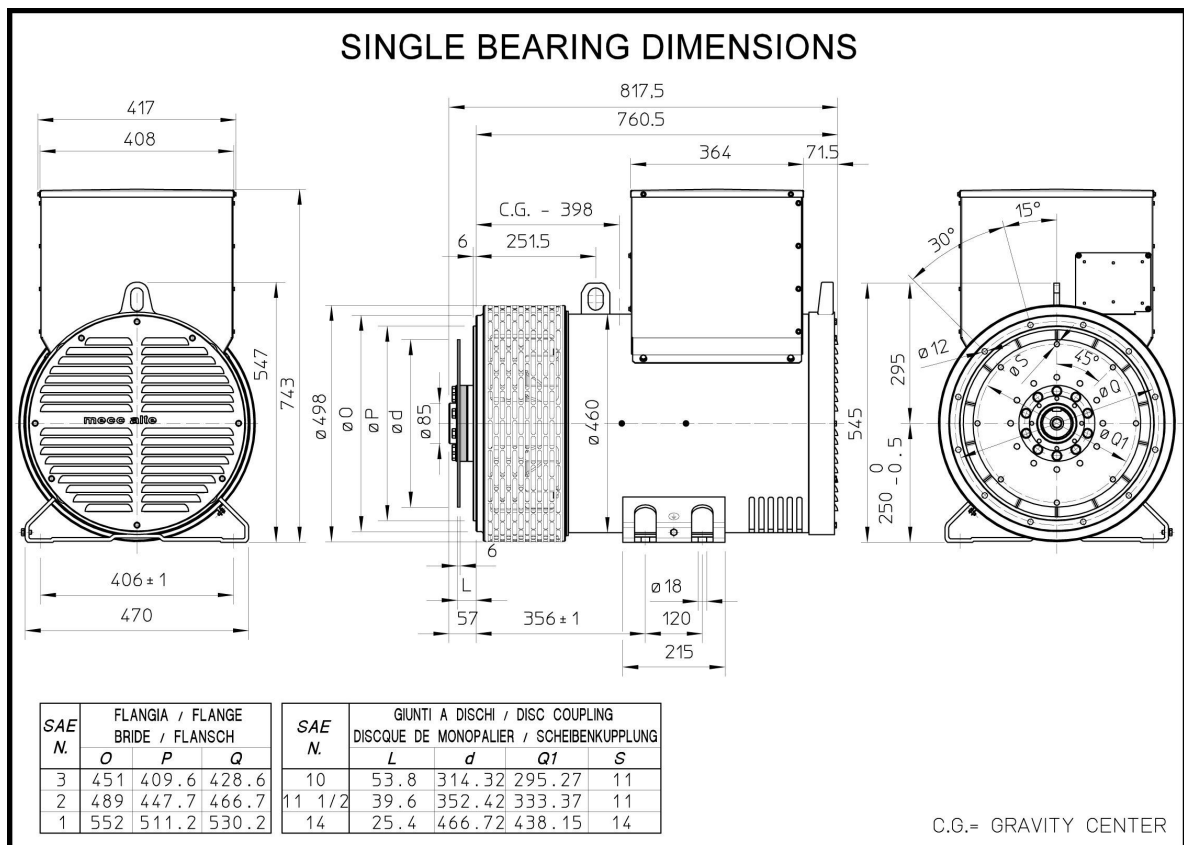
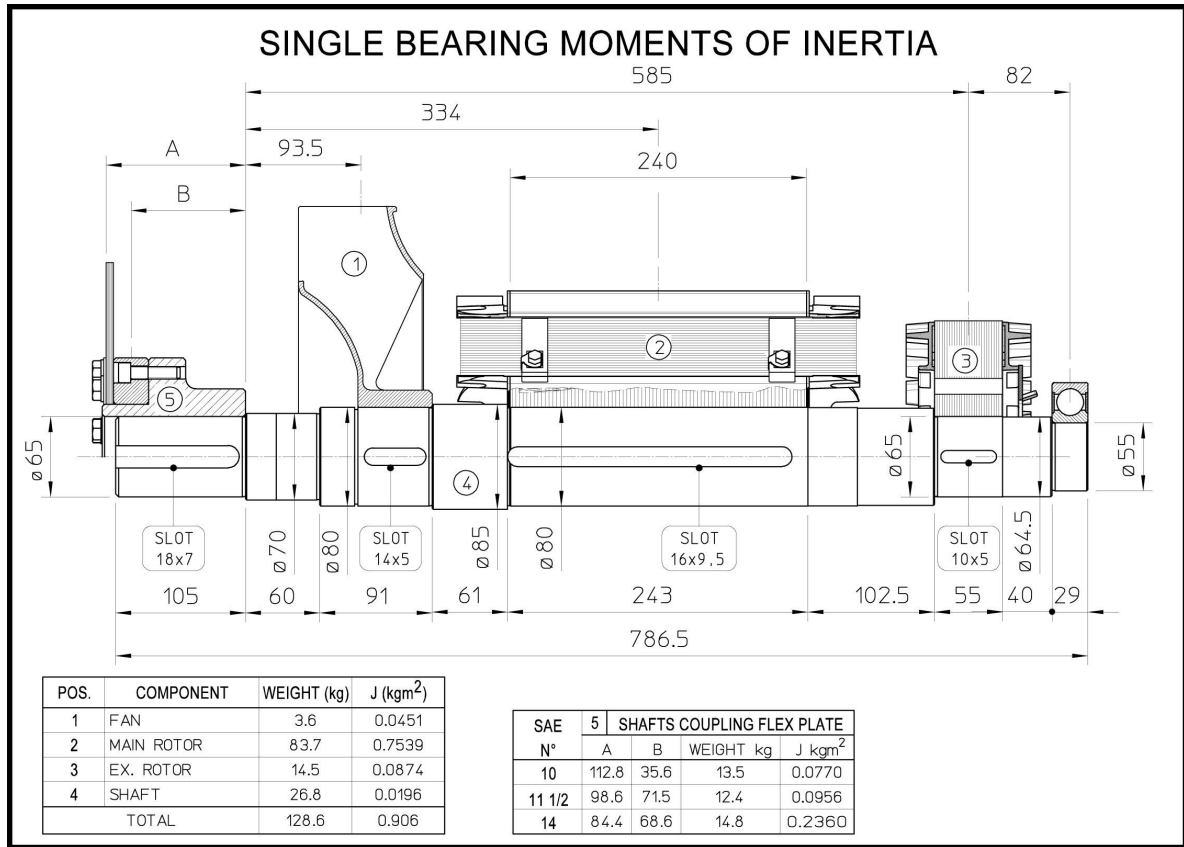

ECP34-1L/4 A

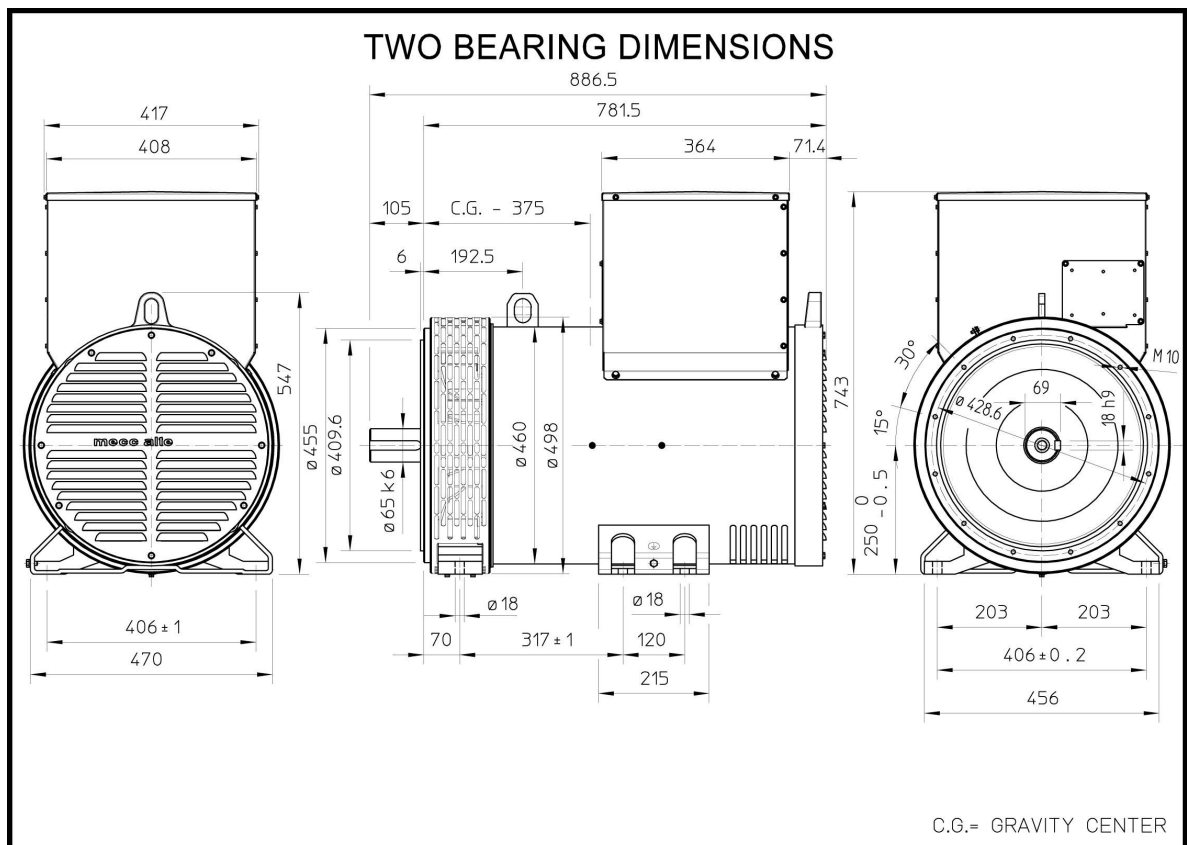
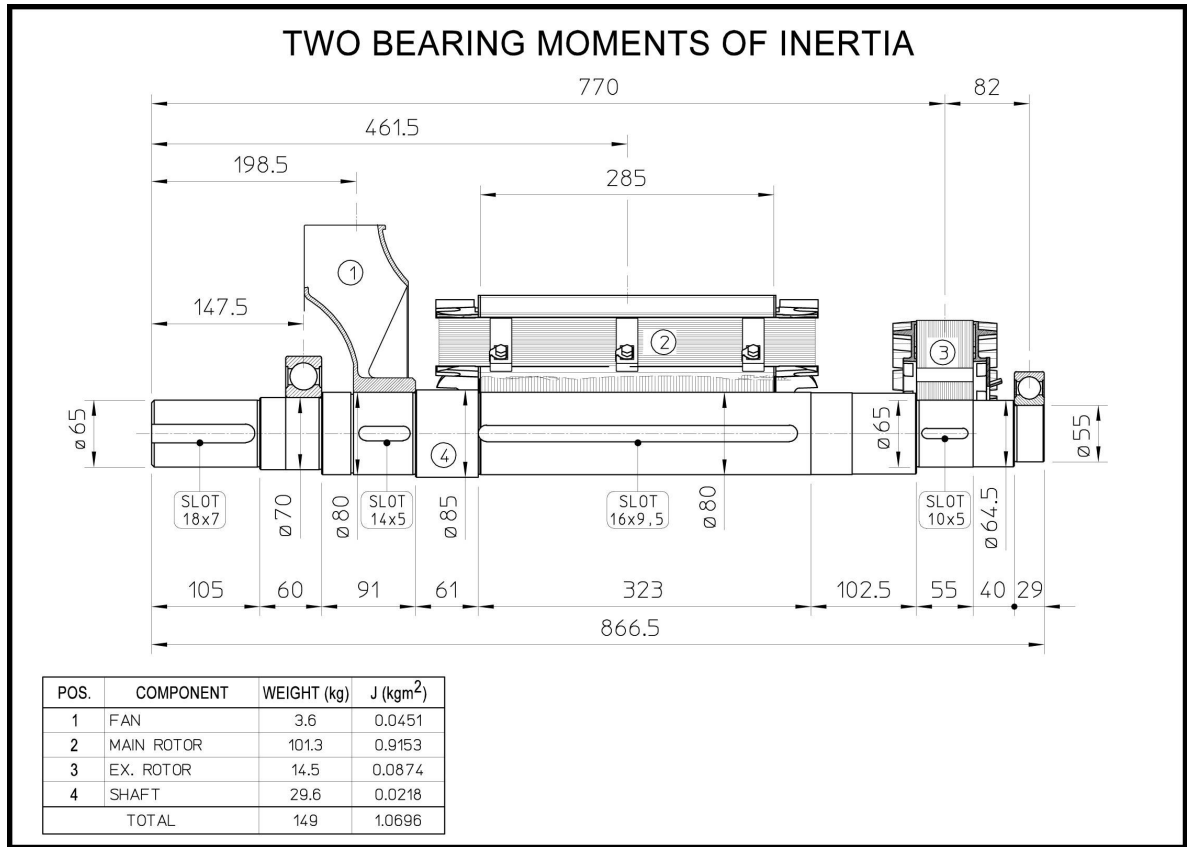

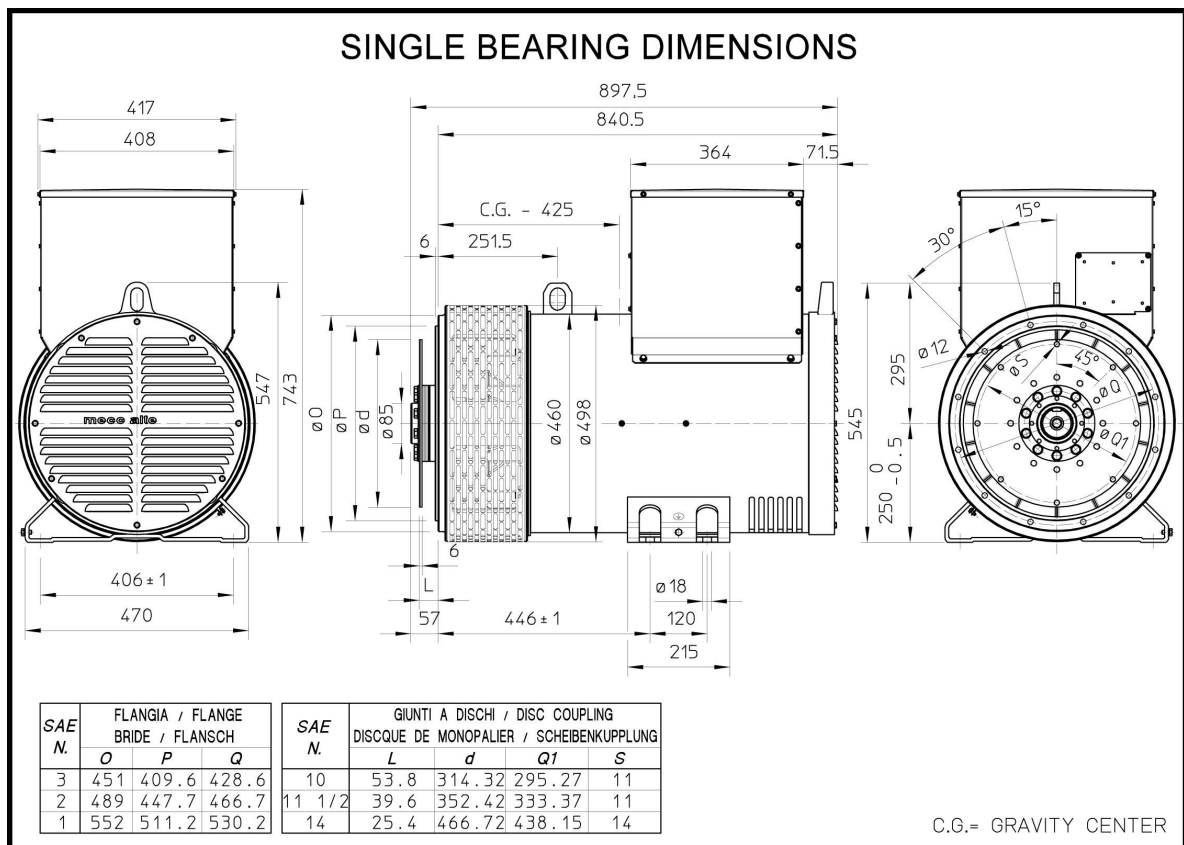
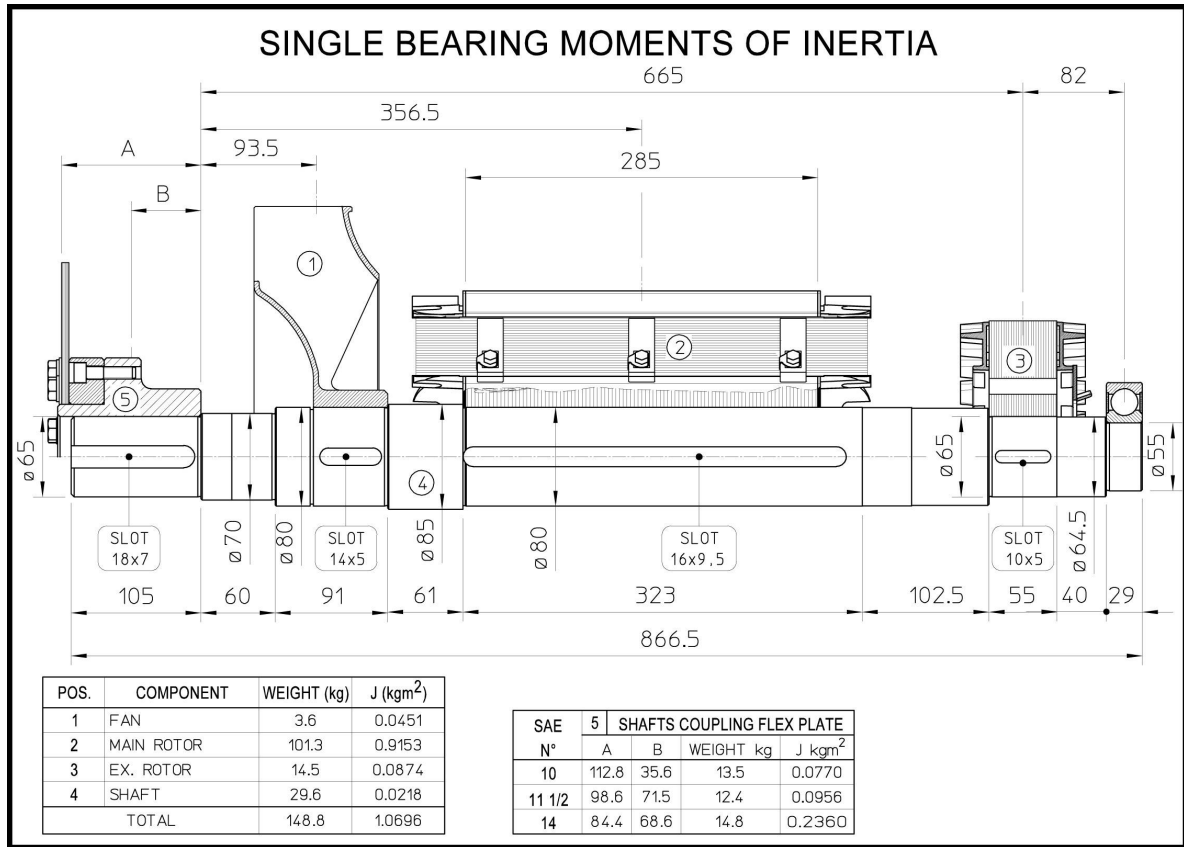

ECP34-2L/4 A

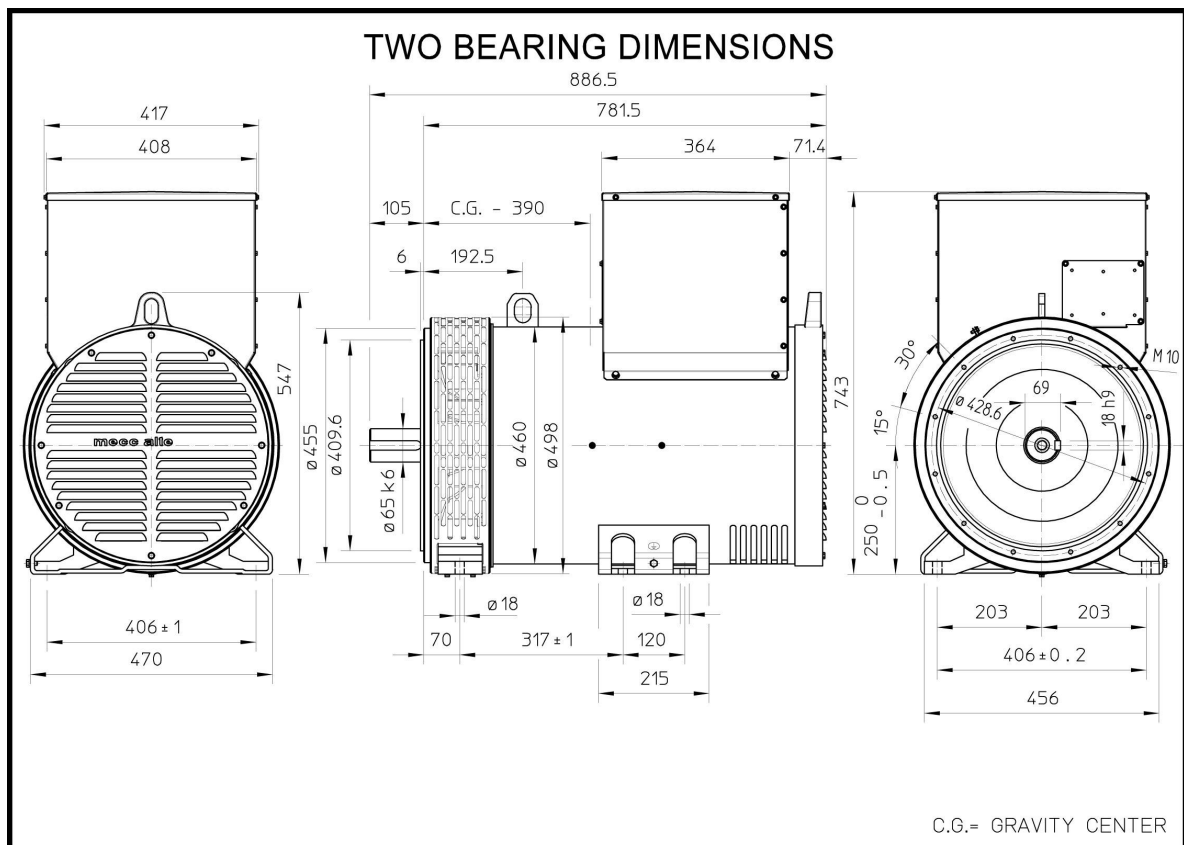
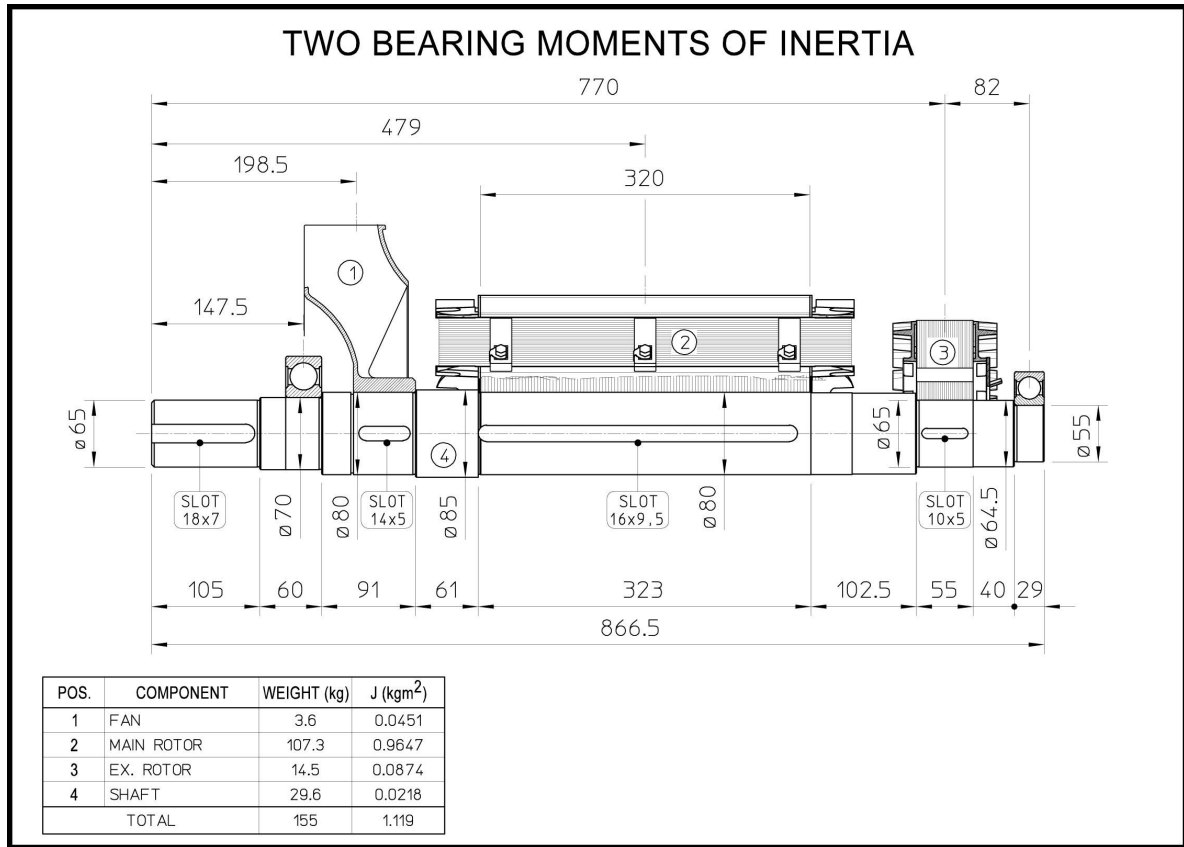

ECP34-2L/4 A

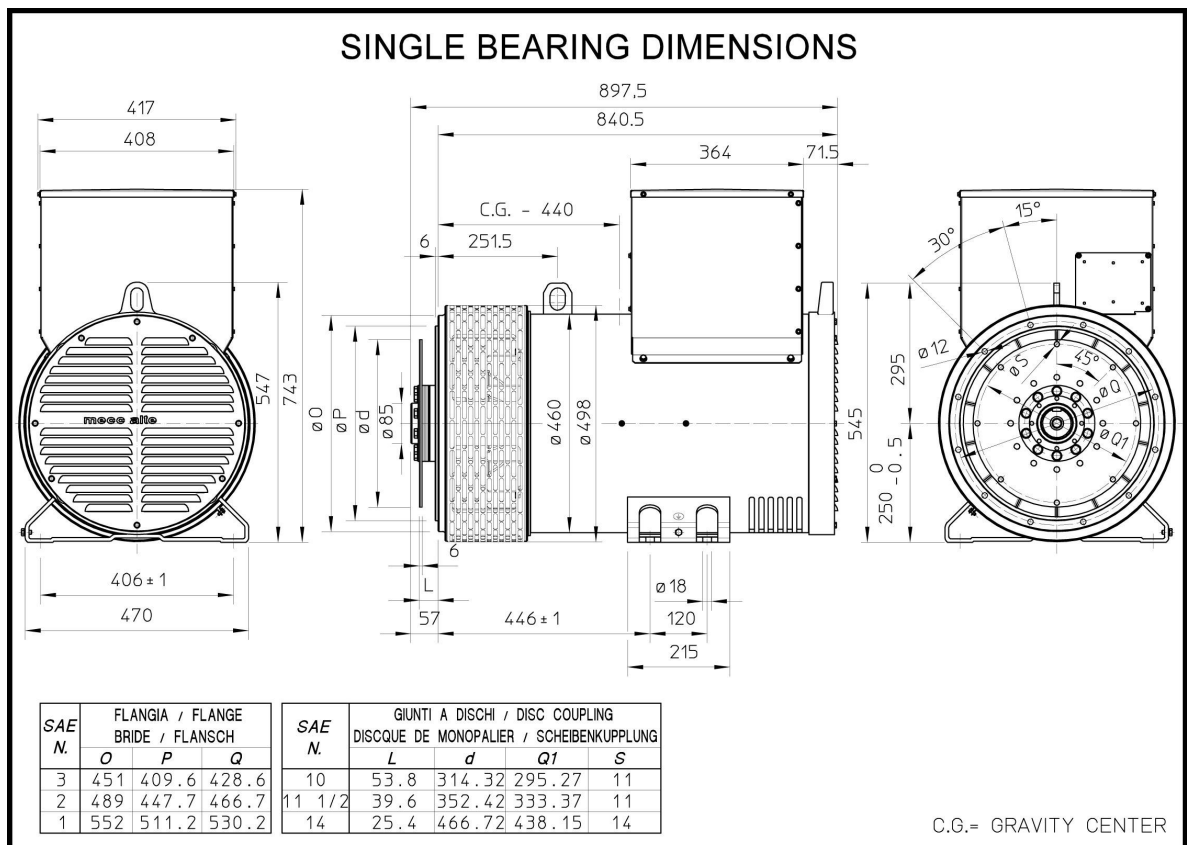
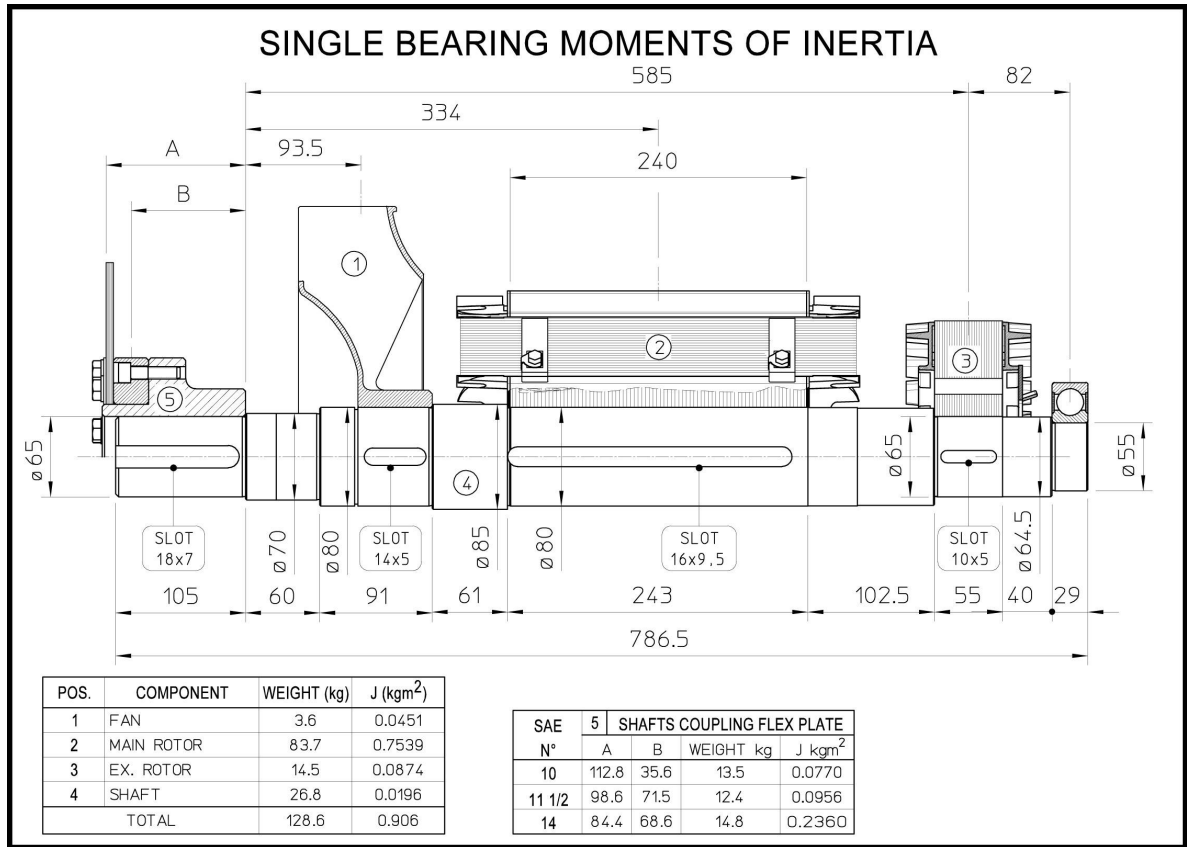

ECP34-3L/4 A

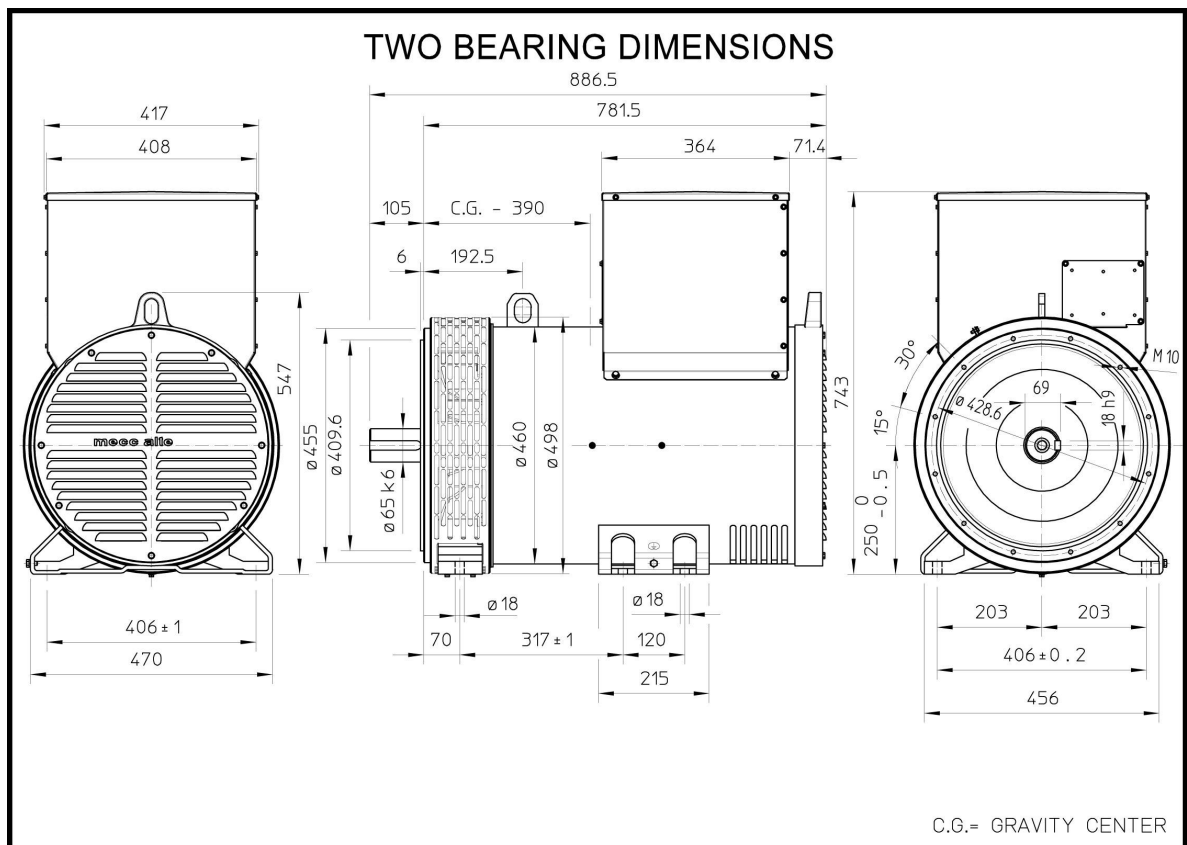
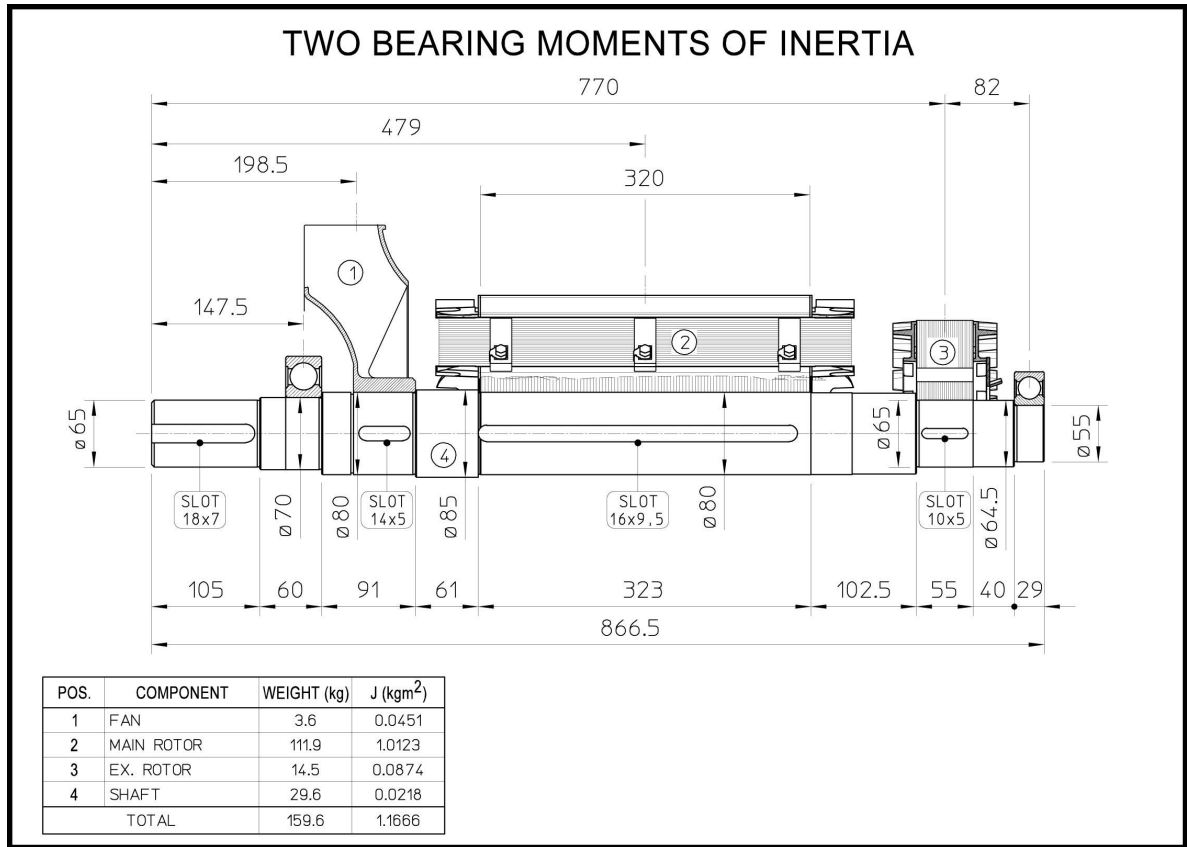

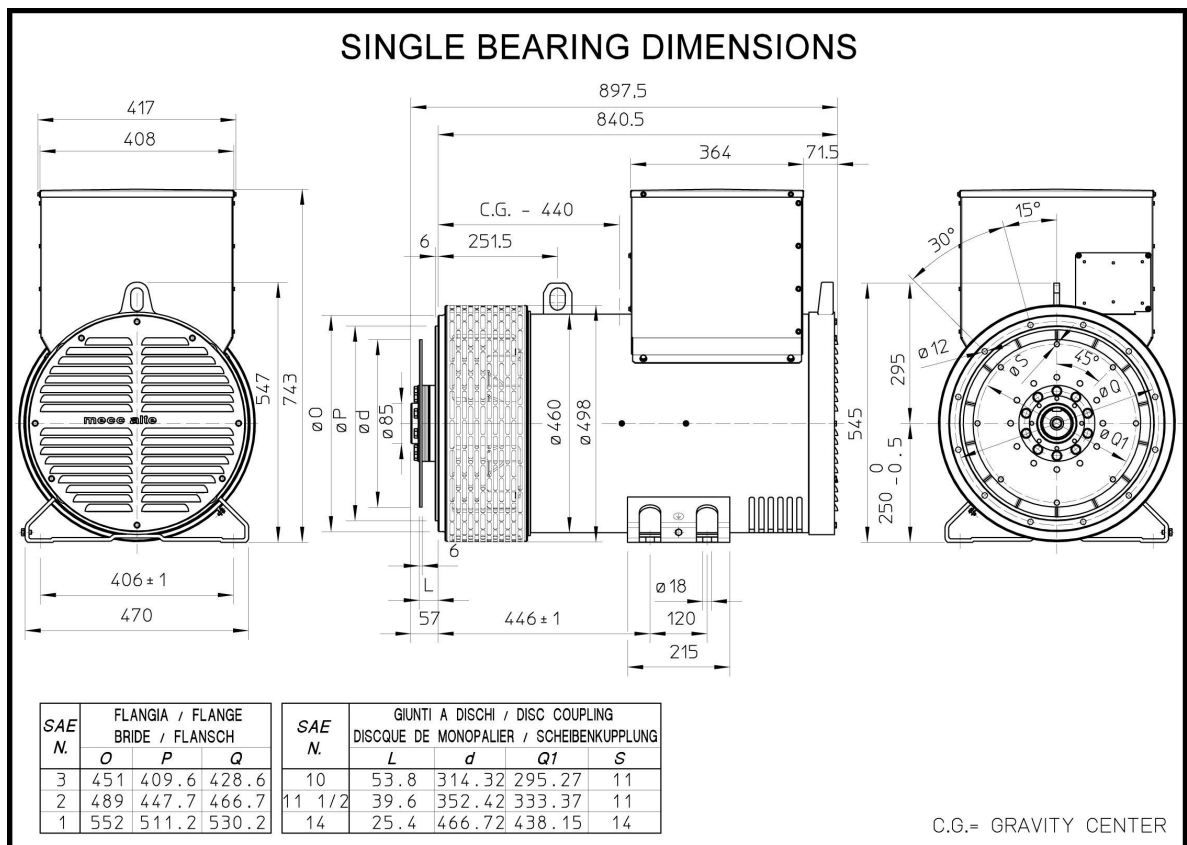
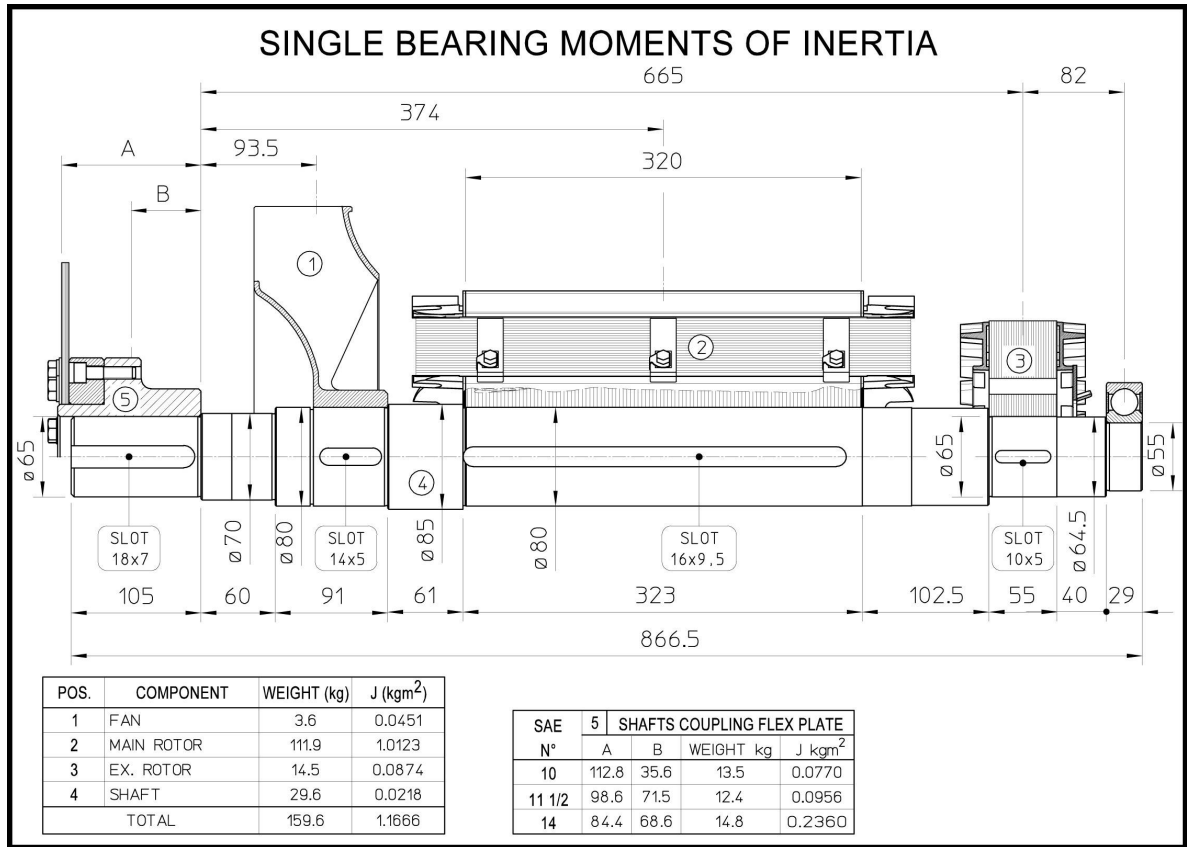

Mecc Alte SpA (HQ)

Via Roma
20 - 36051 Creazzo
Vicenza - ITALY
T: +39 0444 396111
F: +39 0444 396166
E: info@meccalte.it
aftersales@meccalte.it

Mecc Alte Portable

Via Roma
20 - 36051 Creazzo
Vicenza - ITALY
T: +39 0444 396111
F: +39 0444 396166
E: info@meccalte.it
aftersales@meccalte.it

Mecc Alte Power Products srl

Via Melaro
2 - 36075 Montecchio
Maggiore (VI) - ITALY
T: +39 0444 1831295
F: +39 0444 1831306
E: info@meccalte.it
aftersales@meccalte.it

Zanardi Alternatori srl

Via Dei Laghi
48/B - 36077 Altavilla
Vicenza - ITALY
T: +39 0444 370799
F: +39 0444 370330
E: info@zanardialternatori.it

United Kingdom

Mecc Alte U.K. LTD
6 Lands' End Way
Oakham
Rutland, LE15 6RF
T: +44 (0) 1572 771160
F: +44 (0) 1572 771161
E: info@meccalte.co.uk
aftersales@meccalte.co.uk

Spain

Mecc Alte España S.A.
C/ Rio Taibilla, 2
Polig. Ind. Los Valeros
03178 Benijofar (Alicante)
T: +34 (0) 96 6702152
F: +34 (0) 96 6700103
E: info@meccalte.es
aftersales@meccalte.es

China

Mecc Alte Alternator Haimen LTD
755 Nanhai East Rd
Jiangsu HEDZ 226100 PRC
T: +86 (0) 513 82325758
F: +86 (0) 513 82325768
E: info@meccalte.cn
aftersales@meccalte.cn

India

Mecc Alte India PVT LTD
Plot NO: 1, Sanaswadi
Talegaon
Dhamdhare Road Taluka:
Shirur, District:
Pune - 412208
Maharashtra, India
T: +91 2137 619600
F: +91 2137 619699
E: info@meccalte.in
aftersales@meccalte.in

U.S.A. and Canada

Mecc Alte Inc.
1229 Adams Drive
McHenry, IL, 60051
T: +1 815 344 0530
F: +1 815 344 0535
E: info@meccalte.us
aftersales@meccalte.us

Germany

Mecc Alte Generatoren GmbH
Ensener Weg 21
D-51149 Köln
T: +49 (0) 2203 503810
F: +49 (0) 2203 503796
E: info@meccalte.de
aftersales@meccalte.de

Australia

Mecc Alte Alternators PTY LTD
10 Duncan Road, PO Box 1046
Dry Creek, 5094, South
Australia
T: +61 (0) 8 8349 8422
F: +61 (0) 8 8349 8455
E: info@meccalte.com.au
aftersales@meccalte.com.au

France

Mecc Alte International S.A.
Z.E. La Gagnerie
16330 ST.Amant de Boixe
T: +33 (0) 545 397562
F: +33 (0) 545 398820
E: info@meccalte.fr
aftersales@meccalte.fr

Far East

Mecc Alte (F.E.) PTE LTD
19 Kian Teck Drive
Singapore 628836
T: +65 62 657122
F: +65 62 653991
E: info@meccalte.com.sg
aftersales@meccalte.com.sg



www.meccalte.com